

Алматы (7273)495-231
Ангарск (3955)60-70-56
Архангельск (8182)63-90-72
Астрахань (8512)99-46-04
Барнаул (3852)73-04-60
Белгород (4722)40-23-64
Благовещенск (4162)22-76-07
Брянск (4832)59-03-52
Владивосток (423)249-28-31
Владикавказ (8672)28-90-48
Владимир (4922)49-43-18
Волгоград (844)278-03-48
Вологда (8172)26-41-59
Воронеж (473)204-51-73
Екатеринбург (343)384-55-89

Иваново (4932)77-34-06
Ижевск (3412)26-03-58
Иркутск (395)279-98-46
Казань (843)206-01-48
Калининград (4012)72-03-81
Калуга (4842)92-23-67
Кемерово (3842)65-04-62
Киров (8332)68-02-04
Коломна (4966)23-41-49
Кострома (4942)77-07-48
Краснодар (861)203-40-90
Красноярск (391)204-63-61
Курск (4712)77-13-04
Курган (3522)50-90-47
Липецк (4742)52-20-81

Магнитогорск (3519)55-03-13
Москва (495)268-04-70
Мурманск (8152)59-64-93
Набережные Челны (8552)20-53-41
Нижний Новгород (831)429-08-12
Новокузнецк (3843)20-46-81
Ноябрьск (3496)41-32-12
Новосибирск (383)227-86-73
Омск (3812)21-46-40
Орел (4862)44-53-42
Оренбург (3532)37-68-04
Пенза (8412)22-31-16
Петрозаводск (8142)55-98-37
Псков (8112)59-10-37
Пермь (342)205-81-47

Ростов-на-Дону (863)308-18-15
Рязань (4912)46-61-64
Самара (846)206-03-16
Санкт-Петербург (812)309-46-40
Саратов (845)249-38-78
Севастополь (8692)22-31-93
Саранск (8342)22-96-24
Симферополь (3652)67-13-56
Смоленск (4812)29-41-54
Сочи (862)225-72-31
Ставрополь (8652)20-65-13
Сургут (3462)77-98-35
Сыктывкар (8212)25-95-17
Тамбов (4752)50-40-97
Тверь (4822)63-31-35

Тольятти (8482)63-91-07
Томск (3822)98-41-53
Тула (4872)33-79-87
Тюмень (3452)66-21-18
Ульяновск (8422)24-23-59
Улан-Удэ (3012)59-97-51
Уфа (347)229-48-12
Хабаровск (4212)92-98-04
Чебоксары (8352)28-53-07
Челябинск (351)202-03-61
Череповец (8202)49-02-64
Чита (3022)38-34-83
Якутск (4112)23-90-97
Ярославль (4852)69-52-93

Россия +7(495)268-04-70

Казахстан +7(7172)727-132

Киргизия +996(312)96-26-47

<https://adca.nt-rt.ru/> || acd@nt-rt.ru



AIR ELIMINATORS FOR WATER SYSTEMS AE20



AIR ELIMINATORS FOR WATER SYSTEMS AE20 (Carbon Steel)

DESCRIPTION

The AE20 carbon steel air eliminator removes air from hot and superheated water systems and is also suitable for all liquids compatible with the construction, providing that their specific gravity is not less than 0,75Kg/dm³.

This ball float type automatic air eliminator can be used in combination with other air elimination and separation systems or directly applied at high points in the piping.

Connections are female screwed or flanged for horizontal or vertical installation

MAIN FEATURES

Corrosion resistant working parts.

Replaceable internal parts.

OPTIONS: Internal strainer (only on horizontal models).

USE: Cold, hot and superheated water systems.

AVAILABLE MODELS: AE 20-21

SIZES: DN ½" – 1", DN 15 to DN25.

CONNECTIONS: Female screwed ISO 7/1Rp(BS21).
Flanged EN 1092-1 PN40 or ANSI.
Special flanges upon request.

INSTALLATION Horizontal or vertical installation (on request).It must be installed with the float lever in horizontal plane, so that it rises and falls vertically. It should be installed at the points in the plant where the air tends to collect.

The drain should be piped to a safe position.

See IMI installation and maintenance instructions.

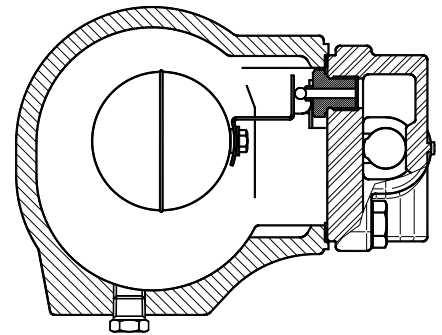

BODY LIMITING CONDITIONS		
FLANGED PN40 / ANSI 300*	FLANGED ANSI 150 **	RELATED TEMP.
ALLOW. PRES.	ALLOW. PRES.	
37,1 bar	15,4 bar	100 °C
33,3 bar	13,8 bar	200 °C
30,4 bar	12,1 bar	250 °C
27,6 bar	10,2 bar	300 °C

PMO - Max. operating pressure 32 bar

TMO - Max. operating temperature 200 °C

* According to EN1092-1:2007 ; ** Acc. to EN1759-1:2004

Body limiting conditions PN40 or below, depending on the type of connection adopted. Rating PN40 for thread, SW and BW.

APPLICATION LIMITS	
Min.Liquid specific weight	0,75 Kg/dm ³
Maximum working dif.pressure-AE20-21	21 bar

FLOW RATE CAPACITY IN N l/m in.												
MODEL	SIZE	DIFFERENTIAL PRESSURE (bar)										
		0,5	1	1,5	2	3	4	6	8	10	15	21
AE20-21	15 - 25	18	32	45	55	75	90	130	180	210	300	430

Capacities at a standard atmospheric pressure of 1bar and 20°C.

If the temperature differs from 15°C, the discharge capacity can be corrected by multiplying it by: $\frac{288}{273 + T}$,
where T is the actual temperature in °C.

DIMENSIONS (mm)											
Screwed						EN PN16/40		ANSI 150		ANSI 300	
SIZE DN	A	B	C	D	WGT. Kgs	F	WGT. Kgs	F	WGT. Kgs	F	WGT. Kgs
15-1/2"	95	178	23	128	5,2	150	6,7	150	6,2	150	7
20-3/4"	95	178	23	128	5,2	150	7,4	150	6,6	150	8,2
25-1"	95	178	23	128	5,2	160	7,8	160	7,4	160	9

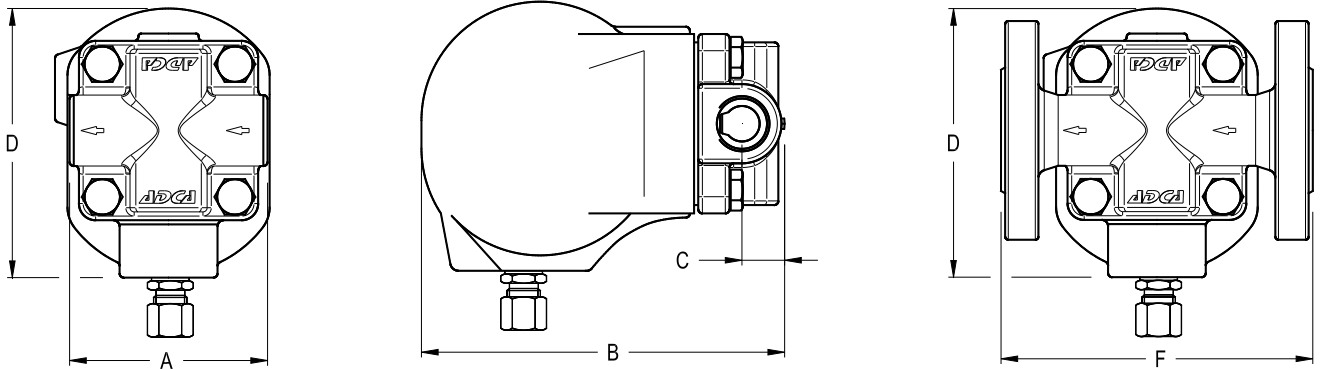

MATERIALS		
POS.Nr.	DESIGNATION	MATERIAL
1	Body	GP240GH / 1.0619
2	Cover	GP240GH / 1.0619
3	*Gasket	Stainless st. / Graphite
4	*Seat	AISI 410 / 1.4006
5	*Valve	VITON
		**AISI 410 / 1.4006
6	*Lever	AISI 304 / 1.4301
7	*Float	AISI 304 / 1.4301
8	Compression fitting	Fe / Zn 12 - ISO 2081
9	Bolts	Steel 8.8

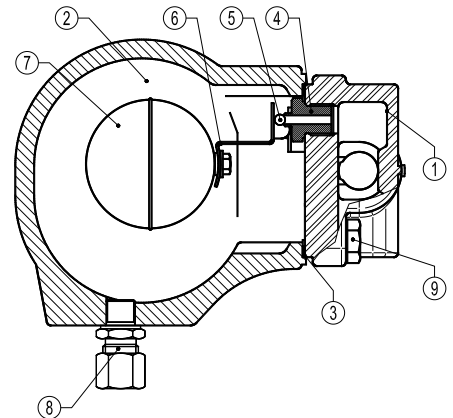

* Available spare parts. ** Optional

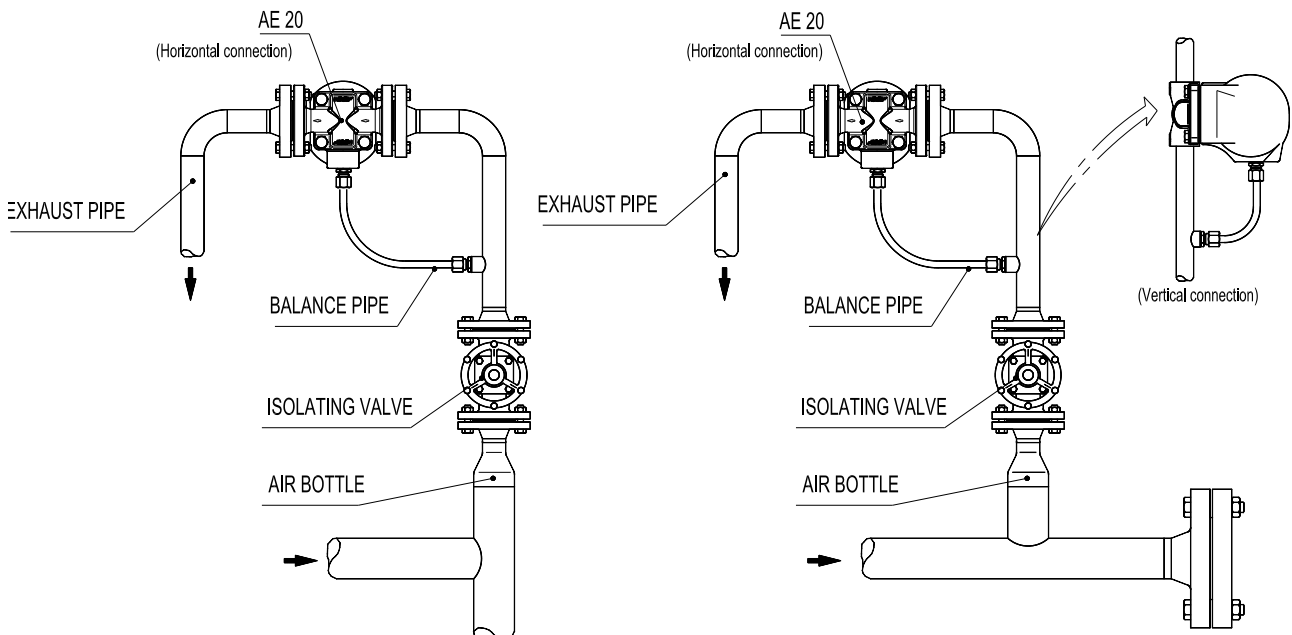

Алматы (7273)495-231
Ангарск (3955)60-70-56
Архангельск (8182)63-90-72
Астрахань (8512)99-46-04
Барнаул (3852)73-04-60
Белгород (4722)40-23-64
Благовещенск (4162)22-76-07
Брянск (4832)59-03-52
Владивосток (423)249-28-31
Владикавказ (8672)28-90-48
Владимир (4922)49-43-18
Волгоград (844)278-03-48
Вологда (8172)26-41-59
Воронеж (473)204-51-73
Екатеринбург (343)384-55-89

Иваново (4932)77-34-06
Ижевск (3412)26-03-58
Иркутск (395)279-98-46
Казань (843)206-01-48
Калининград (4012)72-03-81
Калуга (4842)92-23-67
Кемерово (3842)65-04-62
Киров (8332)68-02-04
Коломна (4966)23-41-49
Кострома (4942)77-07-48
Краснодар (861)203-40-90
Красноярск (391)204-63-61
Курск (4712)77-13-04
Курган (3522)50-90-47
Липецк (4742)52-20-81

Магнитогорск (3519)55-03-13
Москва (495)268-04-70
Мурманск (8152)59-64-93
Набережные Челны (8552)20-53-41
Нижний Новгород (831)429-08-12
Новокузнецк (3843)20-46-81
Ноябрьск (3496)41-32-12
Новосибирск (383)227-86-73
Омск (3812)21-46-40
Орел (4862)44-53-42
Оренбург (3532)37-68-04
Пенза (8412)22-31-16
Петрозаводск (8142)55-98-37
Псков (8112)59-10-37
Пермь (342)205-81-47

Ростов-на-Дону (863)308-18-15
Рязань (4912)46-61-64
Самара (846)206-03-16
Санкт-Петербург (812)309-46-40
Саратов (845)249-38-78
Севастополь (8692)22-31-93
Саранск (8342)22-96-24
Симферополь (3652)67-13-56
Смоленск (4812)29-41-54
Сочи (862)225-72-31
Ставрополь (8652)20-65-13
Сургут (3462)77-98-35
Сыктывкар (8212)25-95-17
Тамбов (4752)50-40-97
Тверь (4822)63-31-35

Тольятти (8482)63-91-07
Томск (3822)98-41-53
Тула (4872)33-79-87
Тюмень (3452)66-21-18
Ульяновск (8422)24-23-59
Улан-Удэ (3012)59-97-51
Уфа (347)229-48-12
Хабаровск (4212)92-98-04
Чебоксары (8352)28-53-07
Челябинск (351)202-03-61
Череповец (8202)49-02-64
Чита (3022)38-34-83
Якутск (4112)23-90-97
Ярославль (4852)69-52-93

Россия +7(495)268-04-70

Казахстан +7(7172)727-132

Киргизия +996(312)96-26-47

<https://adca.nt-rt.ru/> || acd@nt-rt.ru