

Алматы (7273)495-231  
Ангарск (3955)60-70-56  
Архангельск (8182)63-90-72  
Астрахань (8512)99-46-04  
Барнаул (3852)73-04-60  
Белгород (4722)40-23-64  
Благовещенск (4162)22-76-07  
Брянск (4832)59-03-52  
Владивосток (423)249-28-31  
Владикавказ (8672)28-90-48  
Владимир (4922)49-43-18  
Волгоград (844)278-03-48  
Вологда (8172)26-41-59  
Воронеж (473)204-51-73  
Екатеринбург (343)384-55-89

Иваново (4932)77-34-06  
Ижевск (3412)26-03-58  
Иркутск (395)279-98-46  
Казань (843)206-01-48  
Калининград (4012)72-03-81  
Калуга (4842)92-23-67  
Кемерово (3842)65-04-62  
Киров (8332)68-02-04  
Коломна (4966)23-41-49  
Кострома (4942)77-07-48  
Краснодар (861)203-40-90  
Красноярск (391)204-63-61  
Курск (4712)77-13-04  
Курган (3522)50-90-47  
Липецк (4742)52-20-81

Магнитогорск (3519)55-03-13  
Москва (495)268-04-70  
Мурманск (8152)59-64-93  
Набережные Челны (8552)20-53-41  
Нижний Новгород (831)429-08-12  
Новокузнецк (3843)20-46-81  
Ноябрьск (3496)41-32-12  
Новосибирск (383)227-86-73  
Омск (3812)21-46-40  
Орел (4862)44-53-42  
Оренбург (3532)37-68-04  
Пенза (8412)22-31-16  
Петрозаводск (8142)55-98-37  
Псков (8112)59-10-37  
Пермь (342)205-81-47

Ростов-на-Дону (863)308-18-15  
Рязань (4912)46-61-64  
Самара (846)206-03-16  
Санкт-Петербург (812)309-46-40  
Саратов (845)249-38-78  
Севастополь (8692)22-31-93  
Саранск (8342)22-96-24  
Симферополь (3652)67-13-56  
Смоленск (4812)29-41-54  
Сочи (862)225-72-31  
Ставрополь (8652)20-65-13  
Сургут (3462)77-98-35  
Сыктывкар (8212)25-95-17  
Тамбов (4752)50-40-97  
Тверь (4822)63-31-35

Тольятти (8482)63-91-07  
Томск (3822)98-41-53  
Тула (4872)33-79-87  
Тюмень (3452)66-21-18  
Ульяновск (8422)24-23-59  
Улан-Удэ (3012)59-97-51  
Уфа (347)229-48-12  
Хабаровск (4212)92-98-04  
Чебоксары (8352)28-53-07  
Челябинск (351)202-03-61  
Череповец (8202)49-02-64  
Чита (3022)38-34-83  
Якутск (4112)23-90-97  
Ярославль (4852)69-52-93

Россия +7(495)268-04-70

Казахстан +7(7172)727-132

Киргизия +996(312)96-26-47

<https://adca.nt-rt.ru/> || [acd@nt-rt.ru](mailto:acd@nt-rt.ru)

# THERMODYNAMIC STEAM TRAPS

## DT42/2



## THERMODYNAMIC STEAM TRAPS DT42/2

### DESCRIPTION

The thermodynamic DT42/2 disc steam traps are compact and lightweight-easy to install traps, excellent for high pressure systems, including steam tracing applications. These traps have only one moving part and offer a wide operating range, without adjustment.

### MAIN FEATURES

Intermittent discharge.  
Operates on superheated steam.  
The seat and disc can be easily replaced in field without removing the trap from the line.  
Unaffected by water hammer and vibrations.  
Built-in easy-to-clean strainer.

**OPTIONS:** Insulation cover.  
Blowdown valve.

**USE:** Saturated and superheated steam.

**AVAILABLE MODELS:** DT42/2 – carbon steel.

**SIZES:** 1/2" to 1" – DN 15 to DN 25.

**CONNECTIONS:** Female threaded ISO 7 Rp or NPT.  
Flanged EN 1092-1 PN 40 or PN 63.  
Flanged ASME B16.5 Class 150 or 300.  
Socket weld (SW) ASME B16.11.  
Butt weld (BW) ASME B16.25 on request.

**INSTALLATION:** Horizontal or vertical installation.  
See IMI – Installation and maintenance instructions.



CE MARKING – GROUP 2 (PED – European Directive)	
PN 63	Category
1/2" to 1" – DN 15 to 25	SEP

BODY LIMITING CONDITIONS			
FLANGED PN 40 / CLASS 300 *	FLANGED PN 63 *	FLANGED CLASS 150 **	RELATED TEMP.
ALLOWABLE PRESSURE	ALLOWABLE PRESSURE	ALLOWABLE PRESSURE	
40 bar	63 bar	19,3 bar	50 °C
35 bar	55,5 bar	15,8 bar	150 °C
30,4 bar	48 bar	12,1 bar	250 °C
27,4 bar	43,5 bar	10,2 bar	300 °C

PMO – Maximum operating pressure: 42 bar;

TMO – Maximum operating temperature: 300 °C;

\* According to EN 1092-1:2018; \*\* According to EN 1759-1:2004.

Body limiting conditions PN 63 or below, depending on the type of connection adopted. Rating PN 63 for threaded, SW and BW versions.

FLOW RATE CAPACITY (kg/h)														
MODEL	SIZE	DIFFERENTIAL PRESSURE (bar)												
		1	3	5	7	9	12	15	18	21	24	30	35	42
DT42/2	1/2" – DN 15	180	250	300	380	430	500	550	590	620	690	730	770	820
DT42/2	3/4" – DN 20	320	450	530	600	690	720	810	850	900	930	950	980	1040
DT42/2	1" – DN 25	320	450	530	600	690	720	810	850	900	930	950	980	1040

Minimum operating pressure: 0,25 bar; Maximum operating backpressure: 80% of upstream pressure.

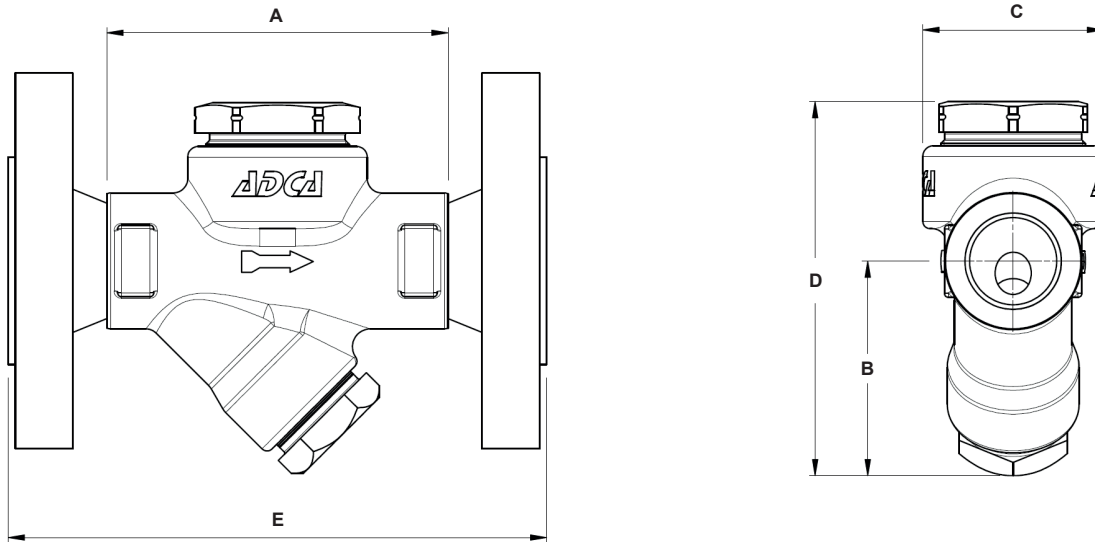

DIMENSIONS (mm)													
SIZE	THREADED / SW					PN 40		PN 63		CLASS 150		CLASS 300	
	A	B	C	D	WEIGHT (kg)	E	WEIGHT (kg)	E	WEIGHT (kg)	E	WEIGHT (kg)	E	WEIGHT (kg)
1/2" – DN 15	95	60	50	104	1,3	150	2,8	150	3,7	150	2,4	150	2,8
3/4" – DN 20	95	60	50	104	1,2	150	3,3	150	5,2	150	2,8	150	3,6
1" – DN 25	95	60	50	110	1,5	160	4	160	6,5	160	3,6	160	4,5

MATERIALS		
POS. N°	DESIGNATION	MATERIAL
1	Body	P250GH / 1.0460
2	Cover	AISI 304 / 1.4301 AISI 303 / 1.4305
3	* Gasket	Stainless steel / Graphite
4	* Seat	Hardened stainless steel
5	* Valve disc	Hardened stainless steel
8	* Tube	AISI 304 / 1.4301
9	* Strainer screen	AISI 304 / 1.4301
10	* Gasket	Stainless steel / Graphite
11	Plug	A105 / 1.0432
12	** Insulation cover	AISI 304 / 1.4301

\* Available spare parts; \*\* Optional.

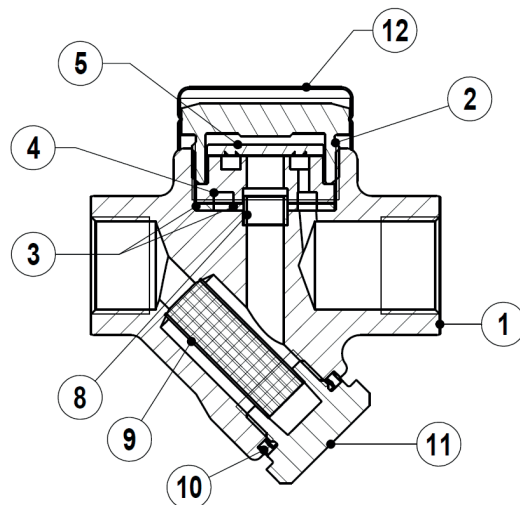

**Алматы** (7273)495-231  
**Ангарск** (3955)60-70-56  
**Архангельск** (8182)63-90-72  
**Астрахань** (8512)99-46-04  
**Барнаул** (3852)73-04-60  
**Белгород** (4722)40-23-64  
**Благовещенск** (4162)22-76-07  
**Брянск** (4832)59-03-52  
**Владивосток** (423)249-28-31  
**Владикавказ** (8672)28-90-48  
**Владимир** (4922)49-43-18  
**Волгоград** (844)278-03-48  
**Вологда** (8172)26-41-59  
**Воронеж** (473)204-51-73  
**Екатеринбург** (343)384-55-89

**Иваново** (4932)77-34-06  
**Ижевск** (3412)26-03-58  
**Иркутск** (395)279-98-46  
**Казань** (843)206-01-48  
**Калининград** (4012)72-03-81  
**Калуга** (4842)92-23-67  
**Кемерово** (3842)65-04-62  
**Киров** (8332)68-02-04  
**Коломна** (4966)23-41-49  
**Кострома** (4942)77-07-48  
**Краснодар** (861)203-40-90  
**Красноярск** (391)204-63-61  
**Курск** (4712)77-13-04  
**Курган** (3522)50-90-47  
**Липецк** (4742)52-20-81

**Магнитогорск** (3519)55-03-13  
**Москва** (495)268-04-70  
**Мурманск** (8152)59-64-93  
**Набережные Челны** (8552)20-53-41  
**Нижний Новгород** (831)429-08-12  
**Новокузнецк** (3843)20-46-81  
**Ноябрьск** (3496)41-32-12  
**Новосибирск** (383)227-86-73  
**Омск** (3812)21-46-40  
**Орел** (4862)44-53-42  
**Оренбург** (3532)37-68-04  
**Пенза** (8412)22-31-16  
**Петрозаводск** (8142)55-98-37  
**Псков** (8112)59-10-37  
**Пермь** (342)205-81-47

**Ростов-на-Дону** (863)308-18-15  
**Рязань** (4912)46-61-64  
**Самара** (846)206-03-16  
**Санкт-Петербург** (812)309-46-40  
**Саратов** (845)249-38-78  
**Севастополь** (8692)22-31-93  
**Саранск** (8342)22-96-24  
**Симферополь** (3652)67-13-56  
**Смоленск** (4812)29-41-54  
**Сочи** (862)225-72-31  
**Ставрополь** (8652)20-65-13  
**Сургут** (3462)77-98-35  
**Сыктывкар** (8212)25-95-17  
**Тамбов** (4752)50-40-97  
**Тверь** (4822)63-31-35

**Тольятти** (8482)63-91-07  
**Томск** (3822)98-41-53  
**Тула** (4872)33-79-87  
**Тюмень** (3452)66-21-18  
**Ульяновск** (8422)24-23-59  
**Улан-Удэ** (3012)59-97-51  
**Уфа** (347)229-48-12  
**Хабаровск** (4212)92-98-04  
**Чебоксары** (8352)28-53-07  
**Челябинск** (351)202-03-61  
**Череповец** (8202)49-02-64  
**Чита** (3022)38-34-83  
**Якутск** (4112)23-90-97  
**Ярославль** (4852)69-52-93

**Россия** +7(495)268-04-70

**Казахстан** +7(7172)727-132

**Киргизия** +996(312)96-26-47