

Алматы (7273)495-231
Ангарск (3955)60-70-56
Архангельск (8182)63-90-72
Астрахань (8512)99-46-04
Барнаул (3852)73-04-60
Белгород (4722)40-23-64
Благовещенск (4162)22-76-07
Брянск (4832)59-03-52
Владивосток (423)249-28-31
Владикавказ (8672)28-90-48
Владимир (4922)49-43-18
Волгоград (844)278-03-48
Вологда (8172)26-41-59
Воронеж (473)204-51-73
Екатеринбург (343)384-55-89

Иваново (4932)77-34-06
Ижевск (3412)26-03-58
Иркутск (395)279-98-46
Казань (843)206-01-48
Калининград (4012)72-03-81
Калуга (4842)92-23-67
Кемерово (3842)65-04-62
Киров (8332)68-02-04
Коломна (4966)23-41-49
Кострома (4942)77-07-48
Краснодар (861)203-40-90
Красноярск (391)204-63-61
Курск (4712)77-13-04
Курган (3522)50-90-47
Липецк (4742)52-20-81

Магнитогорск (3519)55-03-13
Москва (495)268-04-70
Мурманск (8152)59-64-93
Набережные Челны (8552)20-53-41
Нижний Новгород (831)429-08-12
Новокузнецк (3843)20-46-81
Ноябрьск (3496)41-32-12
Новосибирск (383)227-86-73
Омск (3812)21-46-40
Орел (4862)44-53-42
Оренбург (3532)37-68-04
Пенза (8412)22-31-16
Петрозаводск (8142)55-98-37
Псков (8112)59-10-37
Пермь (342)205-81-47

Ростов-на-Дону (863)308-18-15
Рязань (4912)46-61-64
Самара (846)206-03-16
Санкт-Петербург (812)309-46-40
Саратов (845)249-38-78
Севастополь (8692)22-31-93
Саранск (8342)22-96-24
Симферополь (3652)67-13-56
Смоленск (4812)29-41-54
Сочи (862)225-72-31
Ставрополь (8652)20-65-13
Сургут (3462)77-98-35
Сыктывкар (8212)25-95-17
Тамбов (4752)50-40-97
Тверь (4822)63-31-35

Тольятти (8482)63-91-07
Томск (3822)98-41-53
Тула (4872)33-79-87
Тюмень (3452)66-21-18
Ульяновск (8422)24-23-59
Улан-Удэ (3012)59-97-51
Уфа (347)229-48-12
Хабаровск (4212)92-98-04
Чебоксары (8352)28-53-07
Челябинск (351)202-03-61
Череповец (8202)49-02-64
Чита (3022)38-34-83
Якутск (4112)23-90-97
Ярославль (4852)69-52-93

Россия +7(495)268-04-70

Казахстан +7(7172)727-132

Киргизия +996(312)96-26-47

<https://adca.nt-rt.ru/> || acd@nt-rt.ru



WINDOW SIGHT GLASS DW40SS



WINDOW SIGHT GLASS DW40SS (Stainless steel)

DESCRIPTION

For monitoring the right operation of a steam trap, in order to avoid leakages of live steam and, consequently, great energy losses, a sight glass is recommended to be installed downstream of the steam trap. The double window DW40 sight glasses have been designed for this particular application.

- OPTIONS:** Mica shield discs for use with steam.
- USE:** Condensate pipes, downstream of the steam traps.
- AVAILABLE MODELS:** DW40SS – Stainless steel construction.
- SIZES:** 1/2" to 2"; DN 15 to DN 50.
- CONNECTIONS:** Female threaded ISO 7 Rp or NPT.
Flanged EN1092-1 PN40.
Flanged ANSI B16.5 Class 150 lb or 300 lb.
- INSTALLATION:** Horizontal or vertical installation.
See IMI – Installation and maintenance instructions.



1/2" - 1"



1 1/4" - 2"



DN 15 to DN 25

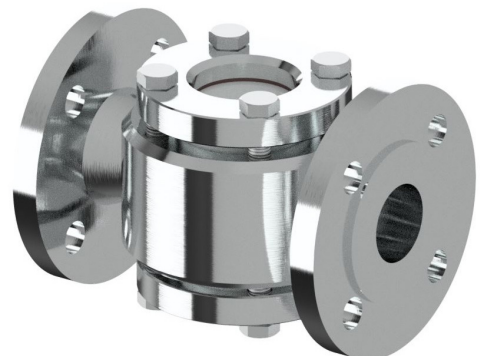

DN 32 to DN 50

BODY LIMITING CONDITIONS			
PN40 / ANSI 300 lb *	PN25 *	ANSI 150 lb **	RELATED TEMPERATURE
ALLOWABLE PRESSURE	ALLOWABLE PRESSURE	ALLOWABLE PRESSURE	
40 bar	25 bar	16,7 bar	-10 / 50 °C
37,9 bar	23,6 bar	15,3 bar	100 °C
34,4 bar	21,5 bar	14 bar	150 °C
31,8 bar	19,8 bar	12,6 bar	200 °C
29,9 bar	18,6 bar	11,7 bar	250 °C

* According to EN1092-1:2018; ** According to EN1759-1:2004.

Remarks: For applications with steam, use mica shield discs;
Rating PN40 for sizes up to DN 25; Rating PN25 for sizes from DN 32 to DN 50.
Rating PN25 for thread, SW or BW.

CE MARKING – GROUP 2 (PED – European Directive)			
PN40 / ANSI 300 lb	PN25	ANSI 150 lb	Category
1/2" to 1" – DN 15 to DN 25	1 1/4" to 1 1/2" – DN 32 to DN 40	1/2" to 2"	SEP
–	2" – DN 50	–	1 (CE Marked)

DIMENSIONS (mm)						
THREADED					FLANGED *	
SIZE	A	B	C	WEIGHT (kg)	D	WEIGHT (kg)
1/2" – DN 15	90	80	60	1,25	150	2,8
3/4" – DN 20	90	80	60	1,25	150	3,4
1" – DN 25	100	87	65	2,1	160	4,7
1 1/4" – DN 32	130	115	114	6,2	180	9,5
1 1/2" – DN 40	130	115	114	6,5	200	10,5
2" – DN 50	130	125	114	7,5	230	12,5

* Values refer to EN1092-1 flanges. For other versions, consult factory.

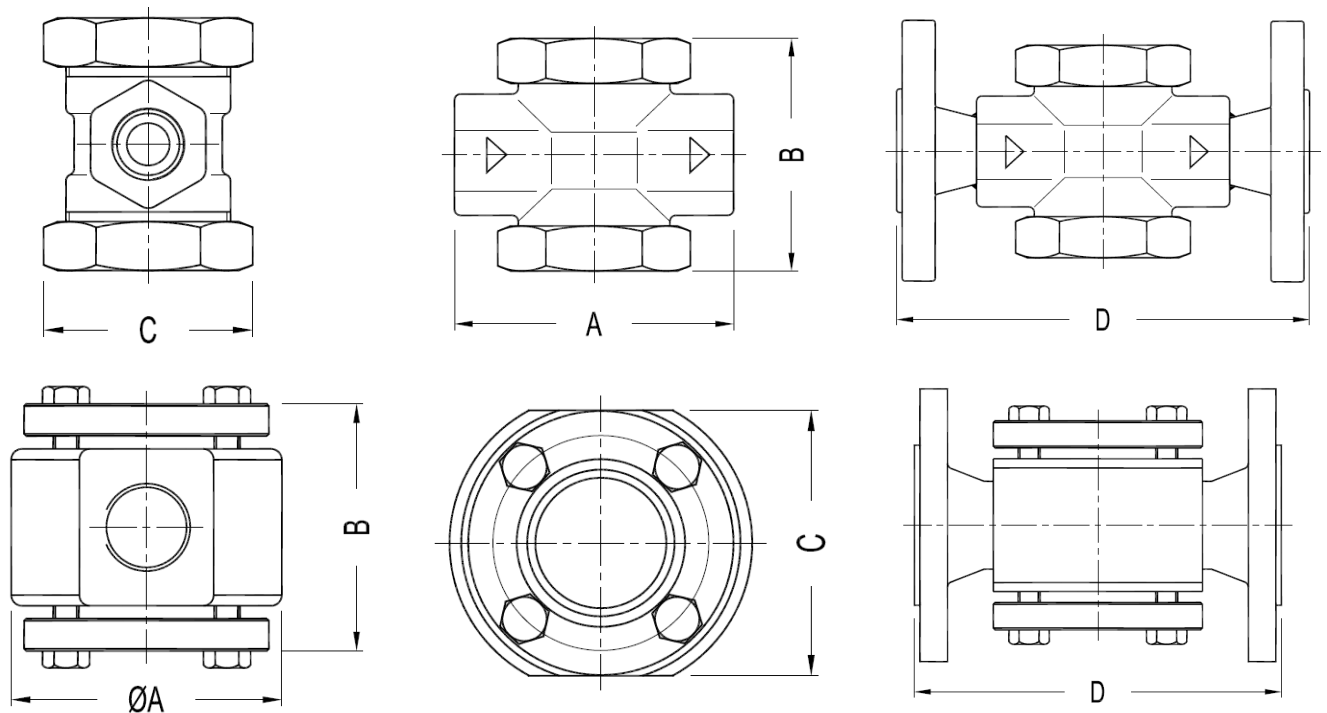

MATERIALS			
POS. Nº	DESIGNATION	1/2" to 1" DN 15 to 25	1 1/4" to 2" DN 32 to DN 50
1	Body	AISI 316L / 1.4404	AISI 316L / 1.4404
2	Glass nut / flange	AISI 316L / 1.4404	AISI 316L / 1.4404
3	* Gasket	Stainless steel / Graphite	Stainless steel / Graphite
4	* Window glass	Tempered borosilicate glass	Tempered borosilicate glass
5	Bolts	–	Stainless steel A-2

* Available spare parts.

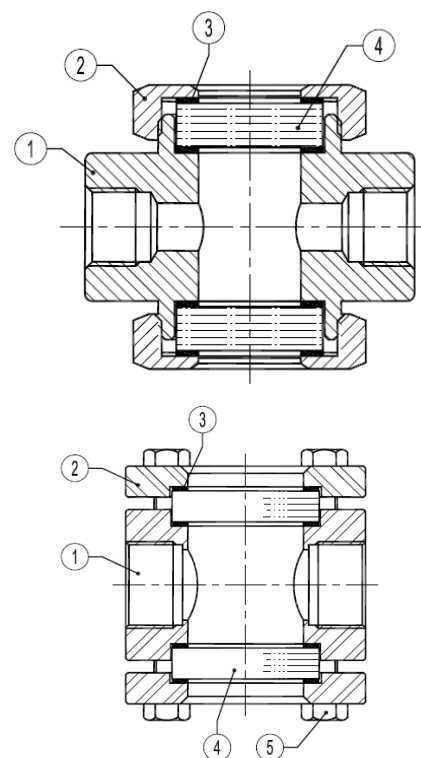

Алматы (7273)495-231
Ангарск (3955)60-70-56
Архангельск (8182)63-90-72
Астрахань (8512)99-46-04
Барнаул (3852)73-04-60
Белгород (4722)40-23-64
Благовещенск (4162)22-76-07
Брянск (4832)59-03-52
Владивосток (423)249-28-31
Владикавказ (8672)28-90-48
Владимир (4922)49-43-18
Волгоград (844)278-03-48
Вологда (8172)26-41-59
Воронеж (473)204-51-73
Екатеринбург (343)384-55-89

Иваново (4932)77-34-06
Ижевск (3412)26-03-58
Иркутск (395)279-98-46
Казань (843)206-01-48
Калининград (4012)72-03-81
Калуга (4842)92-23-67
Кемерово (3842)65-04-62
Киров (8332)68-02-04
Коломна (4966)23-41-49
Кострома (4942)77-07-48
Краснодар (861)203-40-90
Красноярск (391)204-63-61
Курск (4712)77-13-04
Курган (3522)50-90-47
Липецк (4742)52-20-81

Магнитогорск (3519)55-03-13
Москва (495)268-04-70
Мурманск (8152)59-64-93
Набережные Челны (8552)20-53-41
Нижний Новгород (831)429-08-12
Новокузнецк (3843)20-46-81
Ноябрьск (3496)41-32-12
Новосибирск (383)227-86-73
Омск (3812)21-46-40
Орел (4862)44-53-42
Оренбург (3532)37-68-04
Пенза (8412)22-31-16
Петрозаводск (8142)55-98-37
Псков (8112)59-10-37
Пермь (342)205-81-47

Ростов-на-Дону (863)308-18-15
Рязань (4912)46-61-64
Самара (846)206-03-16
Санкт-Петербург (812)309-46-40
Саратов (845)249-38-78
Севастополь (8692)22-31-93
Саранск (8342)22-96-24
Симферополь (3652)67-13-56
Смоленск (4812)29-41-54
Сочи (862)225-72-31
Ставрополь (8652)20-65-13
Сургут (3462)77-98-35
Сыктывкар (8212)25-95-17
Тамбов (4752)50-40-97
Тверь (4822)63-31-35

Тольятти (8482)63-91-07
Томск (3822)98-41-53
Тула (4872)33-79-87
Тюмень (3452)66-21-18
Ульяновск (8422)24-23-59
Улан-Удэ (3012)59-97-51
Уфа (347)229-48-12
Хабаровск (4212)92-98-04
Чебоксары (8352)28-53-07
Челябинск (351)202-03-61
Череповец (8202)49-02-64
Чита (3022)38-34-83
Якутск (4112)23-90-97
Ярославль (4852)69-52-93

Россия +7(495)268-04-70

Казахстан +7(7172)727-132

Киргизия +996(312)96-26-47

<https://adca.nt-rt.ru/> || acd@nt-rt.ru