

Алматы (7273)495-231
Ангарск (3955)60-70-56
Архангельск (8182)63-90-72
Астрахань (8512)99-46-04
Барнаул (3852)73-04-60
Белгород (4722)40-23-64
Благовещенск (4162)22-76-07
Брянск (4832)59-03-52
Владивосток (423)249-28-31
Владикавказ (8672)28-90-48
Владимир (4922)49-43-18
Волгоград (844)278-03-48
Вологда (8172)26-41-59
Воронеж (473)204-51-73
Екатеринбург (343)384-55-89

Иваново (4932)77-34-06
Ижевск (3412)26-03-58
Иркутск (395)279-98-46
Казань (843)206-01-48
Калининград (4012)72-03-81
Калуга (4842)92-23-67
Кемерово (3842)65-04-62
Киров (8332)68-02-04
Коломна (4966)23-41-49
Кострома (4942)77-07-48
Краснодар (861)203-40-90
Красноярск (391)204-63-61
Курск (4712)77-13-04
Курган (3522)50-90-47
Липецк (4742)52-20-81

Магнитогорск (3519)55-03-13
Москва (495)268-04-70
Мурманск (8152)59-64-93
Набережные Челны (8552)20-53-41
Нижний Новгород (831)429-08-12
Новокузнецк (3843)20-46-81
Ноябрьск (3496)41-32-12
Новосибирск (383)227-86-73
Омск (3812)21-46-40
Орел (4862)44-53-42
Оренбург (3532)37-68-04
Пенза (8412)22-31-16
Петрозаводск (8142)55-98-37
Псков (8112)59-10-37
Пермь (342)205-81-47

Ростов-на-Дону (863)308-18-15
Рязань (4912)46-61-64
Самара (846)206-03-16
Санкт-Петербург (812)309-46-40
Саратов (845)249-38-78
Севастополь (8692)22-31-93
Саранск (8342)22-96-24
Симферополь (3652)67-13-56
Смоленск (4812)29-41-54
Сочи (862)225-72-31
Ставрополь (8652)20-65-13
Сургут (3462)77-98-35
Сыктывкар (8212)25-95-17
Тамбов (4752)50-40-97
Тверь (4822)63-31-35

Тольятти (8482)63-91-07
Томск (3822)98-41-53
Тула (4872)33-79-87
Тюмень (3452)66-21-18
Ульяновск (8422)24-23-59
Улан-Удэ (3012)59-97-51
Уфа (347)229-48-12
Хабаровск (4212)92-98-04
Чебоксары (8352)28-53-07
Челябинск (351)202-03-61
Череповец (8202)49-02-64
Чита (3022)38-34-83
Якутск (4112)23-90-97
Ярославль (4852)69-52-93

Россия +7(495)268-04-70

Казахстан +7(7172)727-132

Киргизия +996(312)96-26-47

<https://adca.nt-rt.ru/> || acd@nt-rt.ru



ELECTRIC CONDENSATE RECOVERY UNITS ECRU



ELECTRIC CONDENSATE RECOVERY UNITS ECRU

DESCRIPTION

The ADCAMAT ECRU series electric condensate recovery units are recommended in the transfer of high-temperature water such as hot condensate, to a higher elevation or pressure. This condensate is usually used as boiler feedwater. The standard models are prepared for flows up to 30 m³/h, or higher on request. The units are composed of an horizontal condensate vessel (receiver), a metallic support frame, electric pumps, level controls, valves, prewired control panel and pipework for connections between the different elements of the units.

OPERATION

The condensate is brought into the vessel through the inlet connections, with stainless steel sparge pipes, located on the top of the vessel. As the condensate level rises it will trigger the level control system to start the pumping process. In normal operating conditions, the pumps will work in alternating mode, which means they will alternate duty at the end of each cycle. In the event of a peak load, the level will continue rising eventually triggering the cascading switch which will make both pumps work simultaneously to relieve this peak demand.



MAIN FEATURES

Condensate vessel – Completely manufactured from AISI 316 stainless steel or carbon steel, with inlet connections, overflow, air vents, drain, pump feeding outlets and a magnetic level indicator with bi-stable switches.

Pipework, valves and ancillaries – Includes full bore ball valves at the pump suction ports, manual regulating valves for system head regulation at the pumps discharge, pipework, strainers and pressure gauges.

Metal frame – Manufactured from structural steel (sandblasted and painted) or stainless steel (sandblasted).

Pumps – Manufactured from cast iron or stainless steel, capable of handling hot condensate up to 98 °C and designed for low NPSH.

Control panel – Metal enclosure rated to IP 65 or higher. Features alternating and cascading (simultaneity) functions, pump fault indication for each pump, low and high-level alarms, pump dry run inhibitor, operating mode selector switch and volt-free telemetry terminals for remote stats. The unit requires a 3 phase, 380 to 415 V AC, 50 Hz power supply.

OPTIONS: Thermal insulated vessel.
Full or partial stainless steel construction.
Alternative designs, including ATEX  compliant versions.

AVAILABLE

MODELS: EC225 2T10 – 225L vessel capacity, 2 m³/h flow rate and 10 m delivery head.
EC225 4T10 – 225L vessel capacity, 4 m³/h flow rate and 10 m delivery head.
EC600 10T10 – 600L vessel capacity, 10 m³/h flow rate and 10 m delivery head.
EC600 10T20 – 600L vessel capacity, 10 m³/h flow rate and 20 m delivery head.
EC600 10T30 – 600L vessel capacity, 10 m³/h flow rate and 30 m delivery head.
EC600 20T10 – 600L vessel capacity, 20 m³/h flow rate and 10 m delivery head.
EC850 30T10 – 850L vessel capacity, 30 m³/h flow rate and 10 m delivery head.
EC850 30T20 – 850L vessel capacity, 30 m³/h flow rate and 20 m delivery head.
Others on request.

CERTIFICATION

The ADCAMAT ECRU is designed to operate exclusively at atmospheric pressure and therefore is outside the scope of the European Pressure Equipment Directive. It complies with the European Machinery Directive and therefore carries the CE mark.

When supplied with an integrated control panel the compliance with the Low Voltage Directive and the Electromagnetic Compatibility Devices Directive is also ensured.

A declaration of conformity is delivered with the equipment according with the relevant Directives in use.

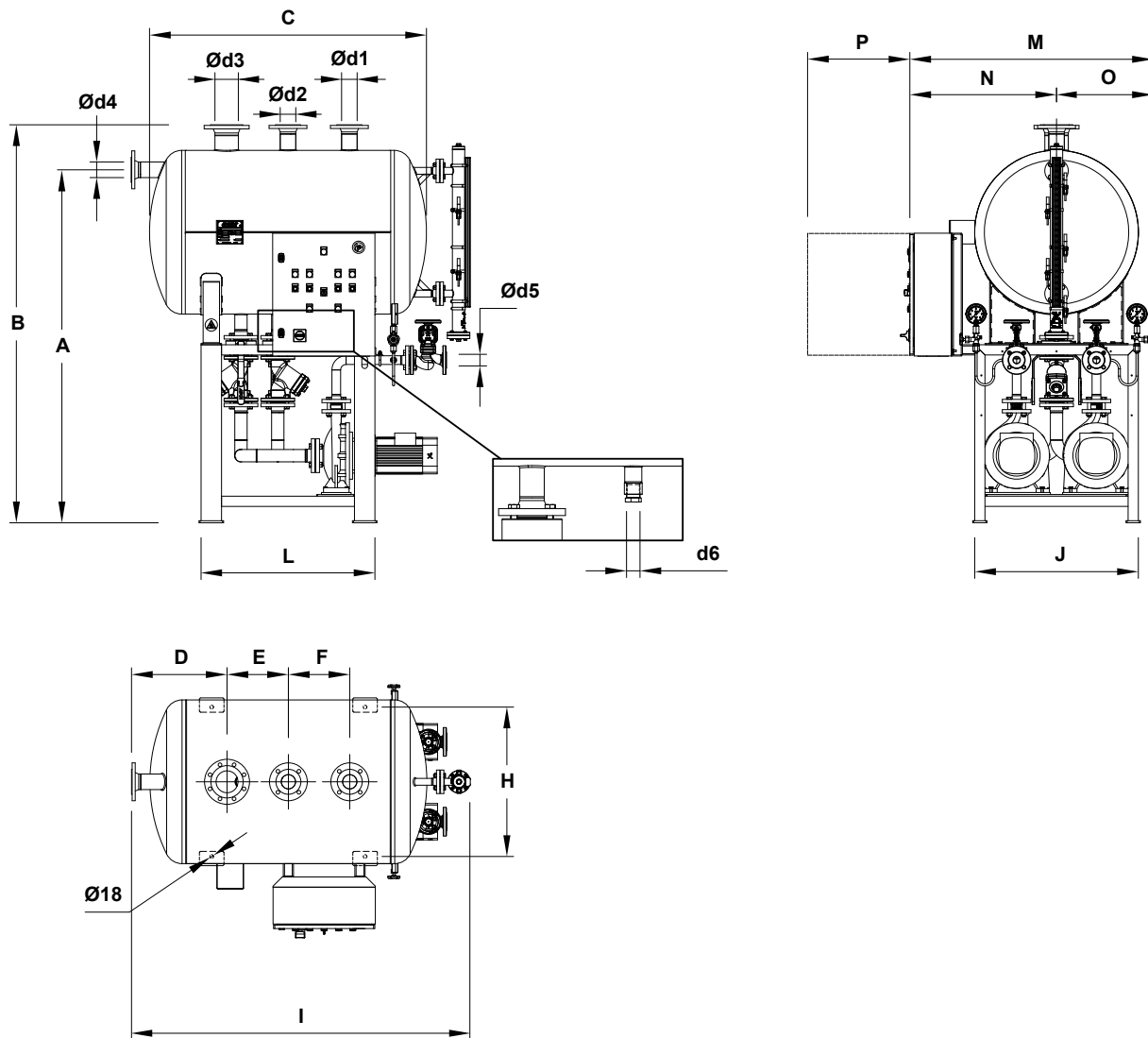

DIMENSIONS (mm) *

MODEL	A	B	C	D	E	F	G	H	I	J	L	M	N	O	P
EC225	1450	1645	1236	423	300	300	750	440	1577,5	500	830	1043	568	475	500
EC600	1725	1945	1354	467	300	300	750	730	1660,5	800	850	1200	727	473	500
EC850	1700	1945	1854	617	400	400	1000	730	2160,5	800	1100	1200	727	473	500

* Dimensions and configuration may vary depending on the model. Dimensions shown refer to units with non-stainless electric pumps.

CONNECTIONS *

MODEL	Ød1	Ød2	Ød3	Ød4	Ød5	d6
EC225 2T10	DN 50	DN 50	DN 80	DN 50	DN 25	1"
EC225 4T10	DN 50	DN 50	DN 80	DN 50	DN 40	1"
EC600 10T10	DN 65	DN 65	DN 100	DN 65	DN 32	1"
EC600 10T20	DN 65	DN 65	DN 100	DN 65	DN 32	1"
EC600 10T30	DN 65	DN 65	DN 100	DN 65	DN 32	1"
EC600 20T10	DN 80	DN 80	DN 100	DN 80	DN 40	1"
EC600 20T20	DN 80	DN 80	DN 100	DN 80	DN 40	1"
EC850 30T10	DN 100	DN 100	DN 100	DN 100	DN 50	1"
EC850 30T20	DN 100	DN 100	DN 100	DN 100	DN 50	1"

* As standard flanged connections are EN 1092-1 PN 16 and female threaded connections are ISO 7 Rp. Flanged connections according to ASME B16.5 Class 150 and female threaded connections according to ASME B1.20.1 (NPT) are available on request.

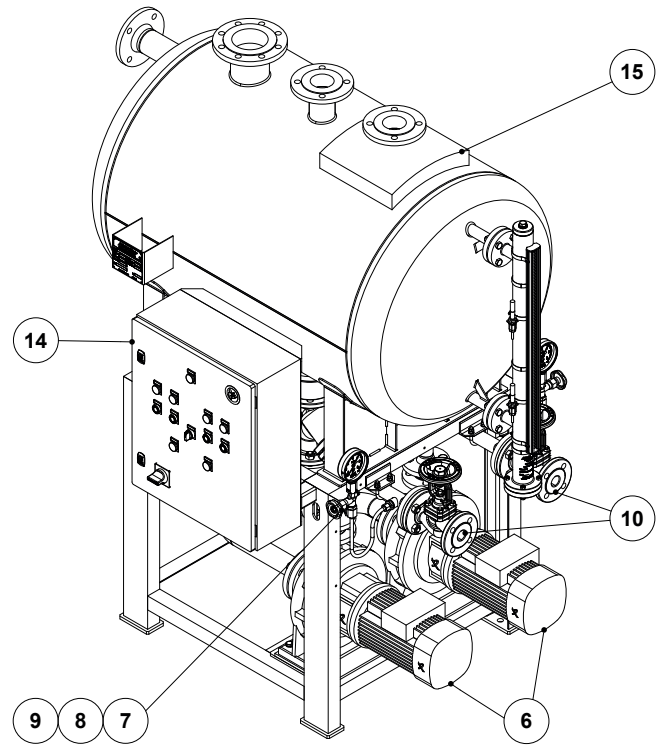
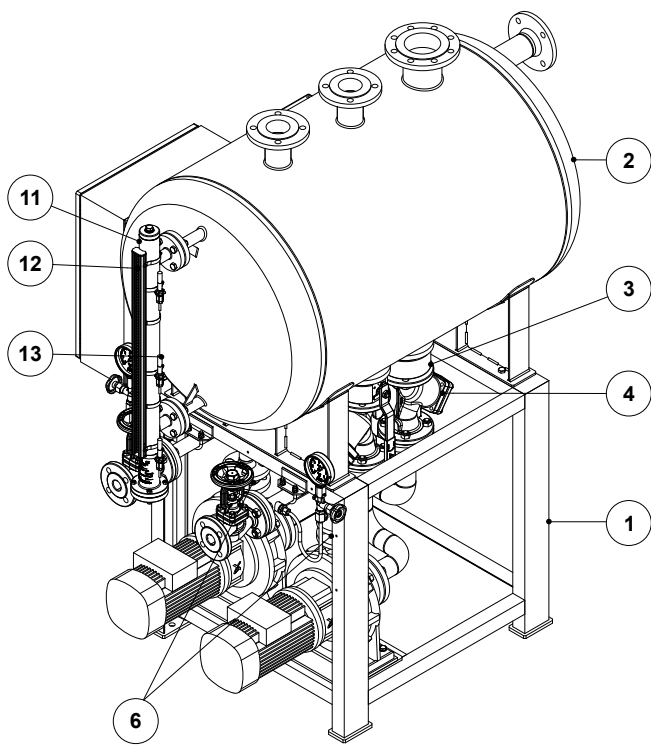

MATERIALS *

POS. N°	DESIGNATION	CARBON STEEL / CAST IRON	STAINLESS STEEL
1	Metal frame	S235JR / 1.0038	AISI304 / 1.4301
2	Vessel	P235GH / 1.0325	AISI 316 / 1.4401
3	Ball valves	ADCA MWS1	ADCA MWi1
4	Strainers	ADCA IS16F	ADCA IS40Ti
5	Electric pumps	GJL-200 / 0.6020 (body); AISI 304 / 1.4301 (impeller)	AISI 304 / 1.4301; AISI 316 / 1.4401
6	Check valves	ADCA RD40	ADCA RD40
7	Pressure gauge	ADCA MAN100	ADCA MAN100
8	Siphon	ADCA GS	ADCA GS
9	Gauge cock	ADCA GC400	ADCA GC400i
10	Globe valve	ADCA VF40	ADCA VF40i
11	Magnetic level indicator	ADCA MLI	ADCA MLI
12	Indicator	ADCA MLI	ADCA MLI
13	Level switch	ADCA MSB	ADCA MSB
14	Control panel	Carbon steel	Stainless steel
15	Thermal insulation **	Rock-wool / Aluminium	Rock-wool / Aluminium

* References shown are merely indicative and can be changed without notice.

** Optional.

ORDERING CODES ECRU										
Model	EC	225	S	S	2T10	S	S	X	X	E
ECRU Electric Condensate Recovery Unit	EC									
Vessel capacity										
225 liters		225								
600 liters		600								
850 liters		850								
Vessel material										
Carbon steel			S							
AISI 316 / 1.4401 stainless steel			I							
Number of electric pumps										
Single pump (non standard) (3~ 380 to 415 V, 50 Hz)				S						
Single pump in stainless steel (non standard) (3~ 380 to 415 V, 50 Hz)				U						
Two pumps (3~ 380 to 415 V, 50 Hz)				D						
Two pumps in stainless steel (3~ 380 to 415 V, 50 Hz)				P						
Maximum flow rate and delivery head in meters at the mentioned flow										
2 m³/h at 10 metres (with 225 L vessel)					2T10					
4 m³/h at 10 metres (with 225 L vessel)					4T10					
10 m³/h at 10 metres (with 600 L vessel)					10T10					
10 m³/h at 20 metres (with 600 L vessel)					10T20					
10 m³/h at 30 metres (with 600 L vessel)					10T30					
20 m³/h at 10 metres (with 600 L vessel)					20T10					
20 m³/h at 20 metres (with 600 L vessel)					20T20					
30 m³/h at 10 metres (with 850 L vessel)					30T10					
30 m³/h at 20 metres (with 850 L vessel)					30T20					
Metal frame										
Fabricated carbon steel						S				
Fabricated stainless steel						I				
Pipework, valves and ancillaries										
Carbon steel or cast iron							S			
Stainless steel pipework with carbon steel or cast iron valves and ancillaries							T			
Stainless steel							I			
Control panel										
Without control panel								X		
Control panel with carbon steel enclosure, magnetic level indicator, bi-stable switches and wiring								E		
Control panel with stainless steel enclosure, magnetic level indicator, bi-stable switches and wiring								I		
Thermal insulation										
Without thermal insulation									X	
Thermal insulation with aluminium cladding									T	
Special valves / Extras										
Full description or additional codes have to be added in case of a non-standard combination										E

Алматы (7273)495-231
Ангарск (3955)60-70-56
Архангельск (8182)63-90-72
Астрахань (8512)99-46-04
Барнаул (3852)73-04-60
Белгород (4722)40-23-64
Благовещенск (4162)22-76-07
Брянск (4832)59-03-52
Владивосток (423)249-28-31
Владикавказ (8672)28-90-48
Владимир (4922)49-43-18
Волгоград (844)278-03-48
Вологда (8172)26-41-59
Воронеж (473)204-51-73
Екатеринбург (343)384-55-89

Иваново (4932)77-34-06
Ижевск (3412)26-03-58
Иркутск (395)279-98-46
Казань (843)206-01-48
Калининград (4012)72-03-81
Калуга (4842)92-23-67
Кемерово (3842)65-04-62
Киров (8332)68-02-04
Коломна (4966)23-41-49
Кострома (4942)77-07-48
Краснодар (861)203-40-90
Красноярск (391)204-63-61
Курск (4712)77-13-04
Курган (3522)50-90-47
Липецк (4742)52-20-81

Магнитогорск (3519)55-03-13
Москва (495)268-04-70
Мурманск (8152)59-64-93
Набережные Челны (8552)20-53-41
Нижний Новгород (831)429-08-12
Новокузнецк (3843)20-46-81
Ноябрьск (3496)41-32-12
Новосибирск (383)227-86-73
Омск (3812)21-46-40
Орел (4862)44-53-42
Оренбург (3532)37-68-04
Пенза (8412)22-31-16
Петрозаводск (8142)55-98-37
Псков (8112)59-10-37
Пермь (342)205-81-47

Ростов-на-Дону (863)308-18-15
Рязань (4912)46-61-64
Самара (846)206-03-16
Санкт-Петербург (812)309-46-40
Саратов (845)249-38-78
Севастополь (8692)22-31-93
Саранск (8342)22-96-24
Симферополь (3652)67-13-56
Смоленск (4812)29-41-54
Сочи (862)225-72-31
Ставрополь (8652)20-65-13
Сургут (3462)77-98-35
Сыктывкар (8212)25-95-17
Тамбов (4752)50-40-97
Тверь (4822)63-31-35

Тольятти (8482)63-91-07
Томск (3822)98-41-53
Тула (4872)33-79-87
Тюмень (3452)66-21-18
Ульяновск (8422)24-23-59
Улан-Удэ (3012)59-97-51
Уфа (347)229-48-12
Хабаровск (4212)92-98-04
Чебоксары (8352)28-53-07
Челябинск (351)202-03-61
Череповец (8202)49-02-64
Чита (3022)38-34-83
Якутск (4112)23-90-97
Ярославль (4852)69-52-93

Россия +7(495)268-04-70

Казахстан +7(7172)727-132

Киргизия +996(312)96-26-47