

Алматы (7273)495-231  
Ангарск (3955)60-70-56  
Архангельск (8182)63-90-72  
Астрахань (8512)99-46-04  
Барнаул (3852)73-04-60  
Белгород (4722)40-23-64  
Благовещенск (4162)22-76-07  
Брянск (4832)59-03-52  
Владивосток (423)249-28-31  
Владикавказ (8672)28-90-48  
Владимир (4922)49-43-18  
Волгоград (844)278-03-48  
Вологда (8172)26-41-59  
Воронеж (473)204-51-73  
Екатеринбург (343)384-55-89

Иваново (4932)77-34-06  
Ижевск (3412)26-03-58  
Иркутск (395)279-98-46  
Казань (843)206-01-48  
Калининград (4012)72-03-81  
Калуга (4842)92-23-67  
Кемерово (3842)65-04-62  
Киров (8332)68-02-04  
Коломна (4966)23-41-49  
Кострома (4942)77-07-48  
Краснодар (861)203-40-90  
Красноярск (391)204-63-61  
Курск (4712)77-13-04  
Курган (3522)50-90-47  
Липецк (4742)52-20-81

Магнитогорск (3519)55-03-13  
Москва (495)268-04-70  
Мурманск (8152)59-64-93  
Набережные Челны (8552)20-53-41  
Нижний Новгород (831)429-08-12  
Новокузнецк (3843)20-46-81  
Ноябрьск (3496)41-32-12  
Новосибирск (383)227-86-73  
Омск (3812)21-46-40  
Орел (4862)44-53-42  
Оренбург (3532)37-68-04  
Пенза (8412)22-31-16  
Петрозаводск (8142)55-98-37  
Псков (8112)59-10-37  
Пермь (342)205-81-47

Ростов-на-Дону (863)308-18-15  
Рязань (4912)46-61-64  
Самара (846)206-03-16  
Санкт-Петербург (812)309-46-40  
Саратов (845)249-38-78  
Севастополь (8692)22-31-93  
Саранск (8342)22-96-24  
Симферополь (3652)67-13-56  
Смоленск (4812)29-41-54  
Сочи (862)225-72-31  
Ставрополь (8652)20-65-13  
Сургут (3462)77-98-35  
Сыктывкар (8212)25-95-17  
Тамбов (4752)50-40-97  
Тверь (4822)63-31-35

Тольятти (8482)63-91-07  
Томск (3822)98-41-53  
Тула (4872)33-79-87  
Тюмень (3452)66-21-18  
Ульяновск (8422)24-23-59  
Улан-Удэ (3012)59-97-51  
Уфа (347)229-48-12  
Хабаровск (4212)92-98-04  
Чебоксары (8352)28-53-07  
Челябинск (351)202-03-61  
Череповец (8202)49-02-64  
Чита (3022)38-34-83  
Якутск (4112)23-90-97  
Ярославль (4852)69-52-93

Россия +7(495)268-04-70

Казахстан +7(7172)727-132

Киргизия +996(312)96-26-47

<https://adca.nt-rt.ru/> || [acd@nt-rt.ru](mailto:acd@nt-rt.ru)



## FORGED STEEL PIPELINE Y STRAINERS IS116



## FORGED STEEL PIPELINE Y STRAINERS IS116

### DESCRIPTION

The IS116 forged steel Y strainers are applicable to all types of steam, water, oil and air systems. Their purpose is to protect traps, regulating valves, piping, etc. from dirt which are often the cause of damage and consequent energy loss of fluid systems. Connections are female screwed or flanged.



- OPTIONS:** Different screen aperture sizes.  
Drain plug or drain valve in strainer cap.
- USE:** Saturated steam, water, oil, air and other compatible fluids.
- AVAILABLE MODELS:** IS116.
- SIZES:** 1/2" to 2"; DN 15 to DN 50.
- SCREENS:** 0,8 mm aperture.
- CONNECTIONS:** Female screwed ISO 7/1 Rp (BS21).  
NPT (ANSI B1.20.1).  
Flanged EN 1092-1 or ANSI.
- INSTALLATION:** Horizontal or vertical downstream installation.  
See IMI – Installation and maintenance instructions.



PMA – Max. allowable pressure: 100 bar (Cl. 800 lb)  
TMA – Max. allowable temperature: 440 °C

How to order: i.e. IS116 1/2" NPT.

CE MARKING – GROUP 2 (PED – European Directive)	
PN100	Category
DN 15 to DN 32	SEP
DN 40 to DN 50	1 (CE marked)

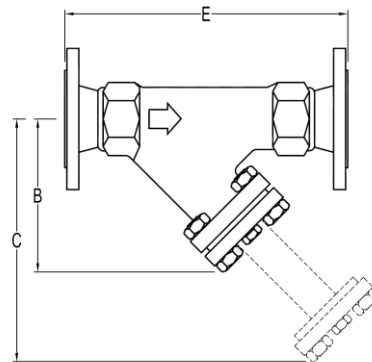
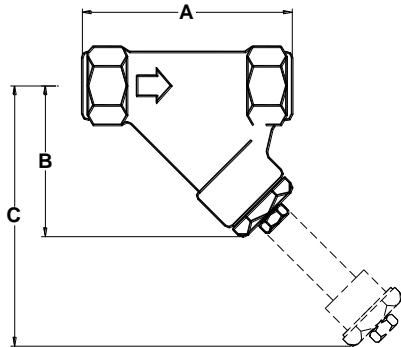

DIMENSIONS (mm)										
Screwed and SW *					PN63/100	ANSI 150 lb	ANSI 300 lb	ANSI 600 lb	PN40	
SIZE	A	B	C	WGT (kg)	E	E	E	E	E	WGT (kg) *
1/2" – DN 15	90	60	105	1	165	165	165	165	150	2,6
3/4" – DN 20	110	75	140	1,2	185	191	191	191	170	3,5
1" – DN 25	130	93	155	2	230	216	216	216	200	4,6
1 1/4" – DN 32	160	120	195	4,5	270	260	270	280	240	8,3
1 1/2" – DN 40	160	120	195	4,5	270	260	270	280	240	9,5
2" – DN 50	160	145	280	6	276	276	292	292	245	12

\* Weight for EN 1092-1 PN40 version only. For other flanged versions weights, consult factory.

MATERIALS		
POS. N°	DESIGNATION	MATERIAL
1	Body	ASTM A105 / 1.0432
2	Cap	ASTM A105 / 1.0432
3	* Gasket	Stainless steel / Graphite
4	* Strainer screen	AISI 304 / 1.4301
5	Bolts	ASTM A193 B7 / A194 2H
6	Drain plug	ASTM A105 / 1.0432

\* Available spare parts (bolted cover, only for 2")

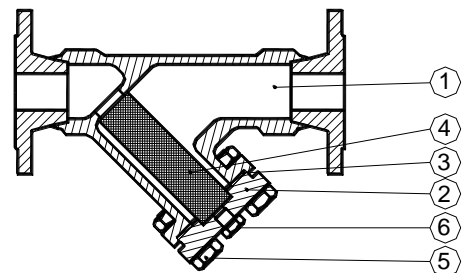
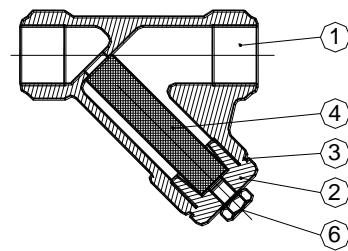

**Алматы** (7273)495-231  
**Ангарск** (3955)60-70-56  
**Архангельск** (8182)63-90-72  
**Астрахань** (8512)99-46-04  
**Барнаул** (3852)73-04-60  
**Белгород** (4722)40-23-64  
**Благовещенск** (4162)22-76-07  
**Брянск** (4832)59-03-52  
**Владивосток** (423)249-28-31  
**Владикавказ** (8672)28-90-48  
**Владимир** (4922)49-43-18  
**Волгоград** (844)278-03-48  
**Вологда** (8172)26-41-59  
**Воронеж** (473)204-51-73  
**Екатеринбург** (343)384-55-89

**Иваново** (4932)77-34-06  
**Ижевск** (3412)26-03-58  
**Иркутск** (395)279-98-46  
**Казань** (843)206-01-48  
**Калининград** (4012)72-03-81  
**Калуга** (4842)92-23-67  
**Кемерово** (3842)65-04-62  
**Киров** (8332)68-02-04  
**Коломна** (4966)23-41-49  
**Кострома** (4942)77-07-48  
**Краснодар** (861)203-40-90  
**Красноярск** (391)204-63-61  
**Курск** (4712)77-13-04  
**Курган** (3522)50-90-47  
**Липецк** (4742)52-20-81

**Магнитогорск** (3519)55-03-13  
**Москва** (495)268-04-70  
**Мурманск** (8152)59-64-93  
**Набережные Челны** (8552)20-53-41  
**Нижний Новгород** (831)429-08-12  
**Новокузнецк** (3843)20-46-81  
**Ноябрьск** (3496)41-32-12  
**Новосибирск** (383)227-86-73  
**Омск** (3812)21-46-40  
**Орел** (4862)44-53-42  
**Оренбург** (3532)37-68-04  
**Пенза** (8412)22-31-16  
**Петрозаводск** (8142)55-98-37  
**Псков** (8112)59-10-37  
**Пермь** (342)205-81-47

**Ростов-на-Дону** (863)308-18-15  
**Рязань** (4912)46-61-64  
**Самара** (846)206-03-16  
**Санкт-Петербург** (812)309-46-40  
**Саратов** (845)249-38-78  
**Севастополь** (8692)22-31-93  
**Саранск** (8342)22-96-24  
**Симферополь** (3652)67-13-56  
**Смоленск** (4812)29-41-54  
**Сочи** (862)225-72-31  
**Ставрополь** (8652)20-65-13  
**Сургут** (3462)77-98-35  
**Сыктывкар** (8212)25-95-17  
**Тамбов** (4752)50-40-97  
**Тверь** (4822)63-31-35

**Тольятти** (8482)63-91-07  
**Томск** (3822)98-41-53  
**Тула** (4872)33-79-87  
**Тюмень** (3452)66-21-18  
**Ульяновск** (8422)24-23-59  
**Улан-Удэ** (3012)59-97-51  
**Уфа** (347)229-48-12  
**Хабаровск** (4212)92-98-04  
**Чебоксары** (8352)28-53-07  
**Челябинск** (351)202-03-61  
**Череповец** (8202)49-02-64  
**Чита** (3022)38-34-83  
**Якутск** (4112)23-90-97  
**Ярославль** (4852)69-52-93

**Россия** +7(495)268-04-70

**Казахстан** +7(7172)727-132

**Киргизия** +996(312)96-26-47

<https://adca.nt-rt.ru/> || [acd@nt-rt.ru](mailto:acd@nt-rt.ru)