

Алматы (7273)495-231
Ангарск (3955)60-70-56
Архангельск (8182)63-90-72
Астрахань (8512)99-46-04
Барнаул (3852)73-04-60
Белгород (4722)40-23-64
Благовещенск (4162)22-76-07
Брянск (4832)59-03-52
Владивосток (423)249-28-31
Владикавказ (8672)28-90-48
Владимир (4922)49-43-18
Волгоград (844)278-03-48
Вологда (8172)26-41-59
Воронеж (473)204-51-73
Екатеринбург (343)384-55-89

Иваново (4932)77-34-06
Ижевск (3412)26-03-58
Иркутск (395)279-98-46
Казань (843)206-01-48
Калининград (4012)72-03-81
Калуга (4842)92-23-67
Кемерово (3842)65-04-62
Киров (8332)68-02-04
Коломна (4966)23-41-49
Кострома (4942)77-07-48
Краснодар (861)203-40-90
Красноярск (391)204-63-61
Курск (4712)77-13-04
Курган (3522)50-90-47
Липецк (4742)52-20-81

Магнитогорск (3519)55-03-13
Москва (495)268-04-70
Мурманск (8152)59-64-93
Набережные Челны (8552)20-53-41
Нижний Новгород (831)429-08-12
Новокузнецк (3843)20-46-81
Ноябрьск (3496)41-32-12
Новосибирск (383)227-86-73
Омск (3812)21-46-40
Орел (4862)44-53-42
Оренбург (3532)37-68-04
Пенза (8412)22-31-16
Петрозаводск (8142)55-98-37
Псков (8112)59-10-37
Пермь (342)205-81-47

Ростов-на-Дону (863)308-18-15
Рязань (4912)46-61-64
Самара (846)206-03-16
Санкт-Петербург (812)309-46-40
Саратов (845)249-38-78
Севастополь (8692)22-31-93
Саранск (8342)22-96-24
Симферополь (3652)67-13-56
Смоленск (4812)29-41-54
Сочи (862)225-72-31
Ставрополь (8652)20-65-13
Сургут (3462)77-98-35
Сыктывкар (8212)25-95-17
Тамбов (4752)50-40-97
Тверь (4822)63-31-35

Тольятти (8482)63-91-07
Томск (3822)98-41-53
Тула (4872)33-79-87
Тюмень (3452)66-21-18
Ульяновск (8422)24-23-59
Улан-Удэ (3012)59-97-51
Уфа (347)229-48-12
Хабаровск (4212)92-98-04
Чебоксары (8352)28-53-07
Челябинск (351)202-03-61
Череповец (8202)49-02-64
Чита (3022)38-34-83
Якутск (4112)23-90-97
Ярославль (4852)69-52-93

Россия +7(495)268-04-70

Казахстан +7(7172)727-132

Киргизия +996(312)96-26-47

<https://adca.nt-rt.ru/> || acd@nt-rt.ru



CAST STEEL PIPELINE T STRAINERS IS40T



CAST STEEL PIPELINE T STRAINERS IS40T DN 15 to DN 100 (EN)

DESCRIPTION

The IS40T cast steel T strainers are applicable to all types of steam, water, oil and air systems. Their purpose is to protect steam traps, regulating valves, pressure reducing valves, piping, etc. from dirt which are often times the cause of damage and consequently energy loss of fluid systems. Connections are flanged.

OPTIONS: Different screen aperture sizes.
Drain plug or drain valve in strainer cap.

USE: Saturated steam, water, oil, air and other compatible fluids.

AVAILABLE MODELS: IS40TS – Carbon steel.
IS40TI – Stainless steel.

SIZES: DN 15 to DN 100.

SCREENS: 0,5 mm aperture up to DN 25.
1,5 mm aperture from DN 32 to DN 80.
2 mm aperture DN 100.

CONNECTIONS: Flanged EN 1092-1 PN40.

INSTALLATION: Horizontal or vertical installation.

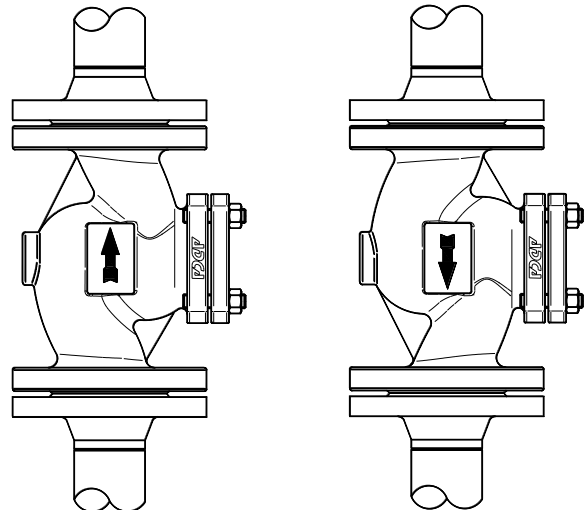
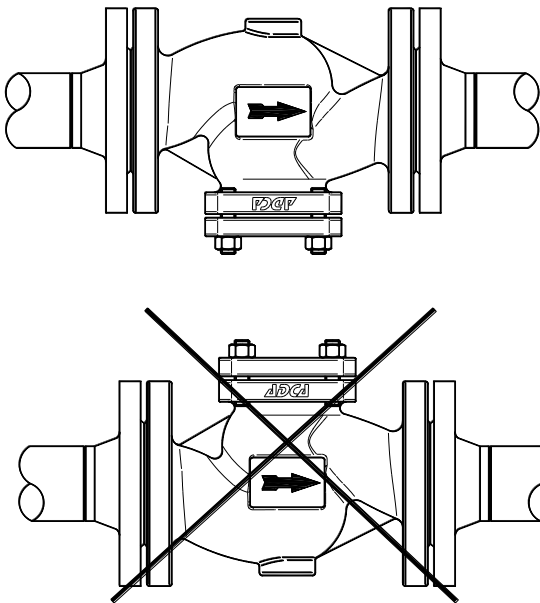

CE MARKING – GROUP 2 (PED – European Directive)

PN16	PN25	PN40	Category
DN 15 to DN 50	DN 15 to DN 40	DN 15 to DN 32	SEP
DN 65 to DN 100	DN 50 to DN 100	DN 40 to DN 100	1 (CE marked)

BODY LIMITING CONDITIONS

IS40TS – PN16 *		IS40TS – PN25 *		IS40TS – PN40 *		IS40TI – PN40 *	
ALLOW. PRESS.	RELATED TEMP.	ALLOW. PRESS.	RELATED TEMP.	ALLOW. PRESS.	RELATED TEMP.	ALLOW. PRESS.	RELATED TEMP.
16 bar	- 10 / 120 °C	25 bar	- 10 / 50 °C	40 bar	- 10 / 50 °C	40 bar	- 10 / 50 °C
13,3 bar	200 °C	20,8 bar	200 °C	33,3 bar	200 °C	33,7 bar	200 °C
12,1 bar	250 °C	19 bar	250 °C	27,6 bar	300 °C	29,7 bar	300 °C
11 bar	300 °C	17,2 bar	300 °C	25,7 bar	350 °C	28,5 bar	350 °C
10,2 bar	350 °C	16 bar	350 °C	23,8 bar	400 °C	27,4 bar	400 °C

* Rating according to EN1092-1:2018.

DIMENSIONS (mm)

SIZE DN	A	B	C	G *	WGT. (kg)
15	130	48	80	1/2"	3,7
20	150	53	80	1/2"	4,2
25	160	58	80	1/2"	5,3
32	180	70	100	1/2"	7,8
40	200	75	105	1/2"	9,6
50	230	83	115	1/2"	14
65	290	93	155	1/2"	23,5
80	310	100	155	1/2"	27,9
100	350	118	165	1/2"	34,6

* Others on request.

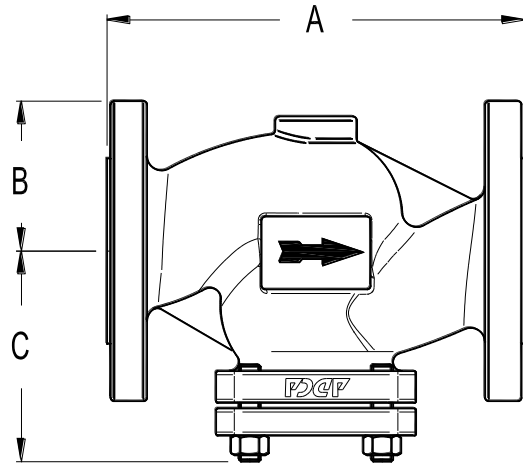

MATERIALS

POS. Nº	DESIGNATION	MATERIAL IS40TS	MATERIAL IS40TI
1	Body	ASTM A216WCB / 1.0619 ; GP240GH / 1.0619	CF8M / 1.4408
2	Centering ring	AISI 304 / 1.4301	AISI 304 / 1.4301
3	Cover	AISI 304 / 1.4301	AISI 304 / 1.4301
4	* Gasket	Stainless steel / Graphite	Stainless steel / Graphite
5	* Screen	AISI 304 / 1.4301	AISI 304 / 1.4301
6	Studs	Steel	A2-70
7	Nuts	Steel	A2-70

* Available spare parts.

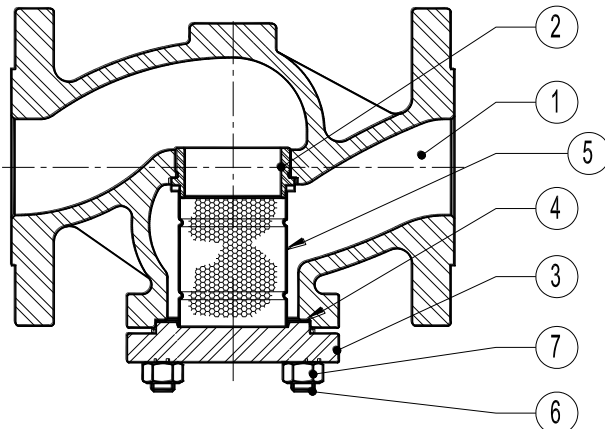
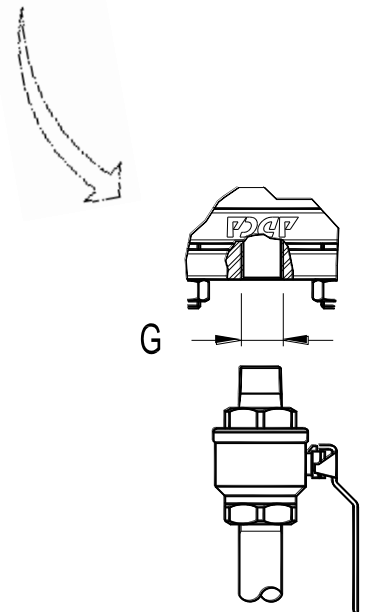

Алматы (7273)495-231
Ангарск (3955)60-70-56
Архангельск (8182)63-90-72
Астрахань (8512)99-46-04
Барнаул (3852)73-04-60
Белгород (4722)40-23-64
Благовещенск (4162)22-76-07
Брянск (4832)59-03-52
Владивосток (423)249-28-31
Владикавказ (8672)28-90-48
Владимир (4922)49-43-18
Волгоград (844)278-03-48
Вологда (8172)26-41-59
Воронеж (473)204-51-73
Екатеринбург (343)384-55-89

Иваново (4932)77-34-06
Ижевск (3412)26-03-58
Иркутск (395)279-98-46
Казань (843)206-01-48
Калининград (4012)72-03-81
Калуга (4842)92-23-67
Кемерово (3842)65-04-62
Киров (8332)68-02-04
Коломна (4966)23-41-49
Кострома (4942)77-07-48
Краснодар (861)203-40-90
Красноярск (391)204-63-61
Курск (4712)77-13-04
Курган (3522)50-90-47
Липецк (4742)52-20-81

Магнитогорск (3519)55-03-13
Москва (495)268-04-70
Мурманск (8152)59-64-93
Набережные Челны (8552)20-53-41
Нижний Новгород (831)429-08-12
Новокузнецк (3843)20-46-81
Ноябрьск (3496)41-32-12
Новосибирск (383)227-86-73
Омск (3812)21-46-40
Орел (4862)44-53-42
Оренбург (3532)37-68-04
Пенза (8412)22-31-16
Петрозаводск (8142)55-98-37
Псков (8112)59-10-37
Пермь (342)205-81-47

Ростов-на-Дону (863)308-18-15
Рязань (4912)46-61-64
Самара (846)206-03-16
Санкт-Петербург (812)309-46-40
Саратов (845)249-38-78
Севастополь (8692)22-31-93
Саранск (8342)22-96-24
Симферополь (3652)67-13-56
Смоленск (4812)29-41-54
Сочи (862)225-72-31
Ставрополь (8652)20-65-13
Сургут (3462)77-98-35
Сыктывкар (8212)25-95-17
Тамбов (4752)50-40-97
Тверь (4822)63-31-35

Тольятти (8482)63-91-07
Томск (3822)98-41-53
Тула (4872)33-79-87
Тюмень (3452)66-21-18
Ульяновск (8422)24-23-59
Улан-Удэ (3012)59-97-51
Уфа (347)229-48-12
Хабаровск (4212)92-98-04
Чебоксары (8352)28-53-07
Челябинск (351)202-03-61
Череповец (8202)49-02-64
Чита (3022)38-34-83
Якутск (4112)23-90-97
Ярославль (4852)69-52-93

Россия +7(495)268-04-70

Казахстан +7(7172)727-132

Киргизия +996(312)96-26-47

<https://adca.nt-rt.ru/> || acd@nt-rt.ru