

Алматы (7273)495-231
Ангарск (3955)60-70-56
Архангельск (8182)63-90-72
Астрахань (8512)99-46-04
Барнаул (3852)73-04-60
Белгород (4722)40-23-64
Благовещенск (4162)22-76-07
Брянск (4832)59-03-52
Владивосток (423)249-28-31
Владикавказ (8672)28-90-48
Владимир (4922)49-43-18
Волгоград (844)278-03-48
Вологда (8172)26-41-59
Воронеж (473)204-51-73
Екатеринбург (343)384-55-89

Иваново (4932)77-34-06
Ижевск (3412)26-03-58
Иркутск (395)279-98-46
Казань (843)206-01-48
Калининград (4012)72-03-81
Калуга (4842)92-23-67
Кемерово (3842)65-04-62
Киров (8332)68-02-04
Коломна (4966)23-41-49
Кострома (4942)77-07-48
Краснодар (861)203-40-90
Красноярск (391)204-63-61
Курск (4712)77-13-04
Курган (3522)50-90-47
Липецк (4742)52-20-81

Магнитогорск (3519)55-03-13
Москва (495)268-04-70
Мурманск (8152)59-64-93
Набережные Челны (8552)20-53-41
Нижний Новгород (831)429-08-12
Новокузнецк (3843)20-46-81
Ноябрьск (3496)41-32-12
Новосибирск (383)227-86-73
Омск (3812)21-46-40
Орел (4862)44-53-42
Оренбург (3532)37-68-04
Пенза (8412)22-31-16
Петрозаводск (8142)55-98-37
Псков (8112)59-10-37
Пермь (342)205-81-47

Ростов-на-Дону (863)308-18-15
Рязань (4912)46-61-64
Самара (846)206-03-16
Санкт-Петербург (812)309-46-40
Саратов (845)249-38-78
Севастополь (8692)22-31-93
Саранск (8342)22-96-24
Симферополь (3652)67-13-56
Смоленск (4812)29-41-54
Сочи (862)225-72-31
Ставрополь (8652)20-65-13
Сургут (3462)77-98-35
Сыктывкар (8212)25-95-17
Тамбов (4752)50-40-97
Тверь (4822)63-31-35

Тольятти (8482)63-91-07
Томск (3822)98-41-53
Тула (4872)33-79-87
Тюмень (3452)66-21-18
Ульяновск (8422)24-23-59
Улан-Удэ (3012)59-97-51
Уфа (347)229-48-12
Хабаровск (4212)92-98-04
Чебоксары (8352)28-53-07
Челябинск (351)202-03-61
Череповец (8202)49-02-64
Чита (3022)38-34-83
Якутск (4112)23-90-97
Ярославль (4852)69-52-93

Россия +7(495)268-04-70

Казахстан +7(7172)727-132

Киргизия +996(312)96-26-47

<https://adca.nt-rt.ru/> || acd@nt-rt.ru



HYGIENIC BALL VALVES M3H TRUE BORE



HYGIENIC BALL VALVES M3H TRUE BORE (DN 10 – 50 DIN)

DESCRIPTION

M3H three pieces body ball valves are isolating valves designed for use with clean steam, condensate and other gases and liquids used in high purity and aseptic processes.

The valve is not designed as a control valve and should only be used as an isolating valve, fully open or fully closed.

The product is mainly designed for the pharmaceutical, biotech, semiconductor, cosmetics, fine chemical, food and beverage industries.

MAIN FEATURES

True bore floating ball design.

A351 CF3M body and ends with ferrite content of less than 2% and low sulphur between 0,005 and 0,017%.

Can be serviced without removal from pipeline.

Tube weld with loose body flanges (360° rotation after installation).

Bidirectional.

Antistatic device.

Anti blow out proof stem.

ISO 5211 mounting.

STANDARD SURFACE FINISH

Internal wetted parts: $\leq 0,51$ micron Ra – SF1.

External: as casted.

Ultrasonic cleaning.

OPTIONS: Different sealing materials.
Degreased for oxygen use.
Cavity filler.

USE: Clean steam, gases and liquids compatible with the construction.

AVAILABLE MODELS: M3H – Investment casting.

SIZES: DN 10 to DN 50.

CONNECTIONS: According to DIN 11850 tube.
TC – Sanitary clamps DIN 32676.
ETO – Extended tube orbital welding.
TC / ETO – Combination.

PACKAGING: Assembling and packaging in a clean room certified according to ISO 14644-1.
The product is end capped and sealed with recyclable thermo-shrinkable plastic film to avoid contamination.

INSTALLATION: See IMI - Installation and maintenance instructions.

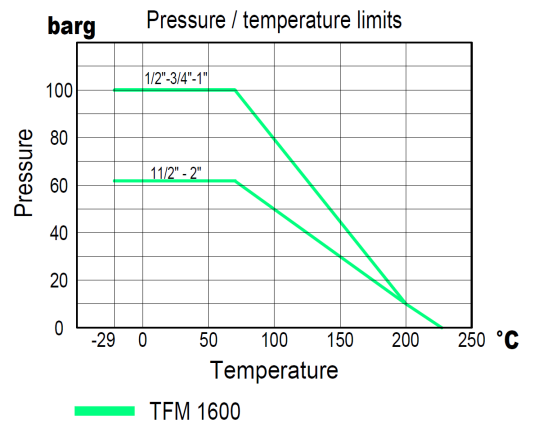

Note: Working pressure may be limited by the valve connections.

CE MARKING – GROUP 2 (PED – European Directive)		
PN63	PN100	Category
–	DN 10 to 20	SEP
DN 25 to 32	–	SEP
DN 40 to 50	–	1 (CE Marked)

DIMENSIONS (mm) DIN

SIZE	A ₁	A ₂	A ₃	A _{3.1}	A _{3.2}	B	C	D	E	F	G	H	I	BALL PORT	ISO 5211	WGT. (kg)
DN 10	90	102	96	45	51	42	21	65	150	34	13	10	25	10	F03	0,73
DN 15	100	114	107	50	57	50	25	69	150	34	19	16	27	16	F03	1,49
DN 20	115	127	121,5	57,5	64	62	31	87	175	34	23	20	27	20	F04	1,94
DN 25	125	135	130,5	62,5	68	72	36	92	175	50,5	29	26	27	26	F04	2,62
DN 32	140	153	147	71	76	85	42,5	114	207	50,5	35	32	27	32	F05	4,41
DN 40	150	161	155	75	80	95	47,5	119	207	50,5	41	38	27	38	F05	5,5
DN 50	165	178	172	82	90	105	52,5	124	232	64	53	50	28	50	F05	7

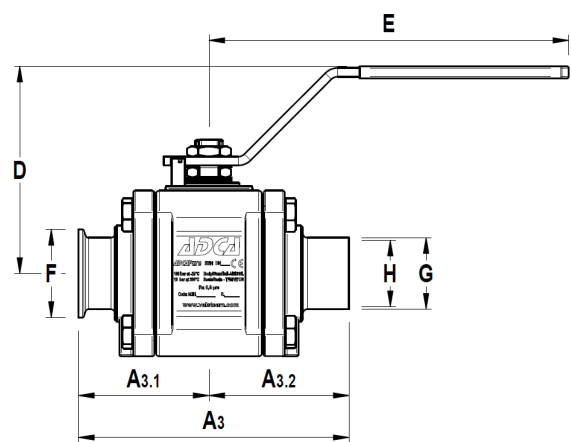
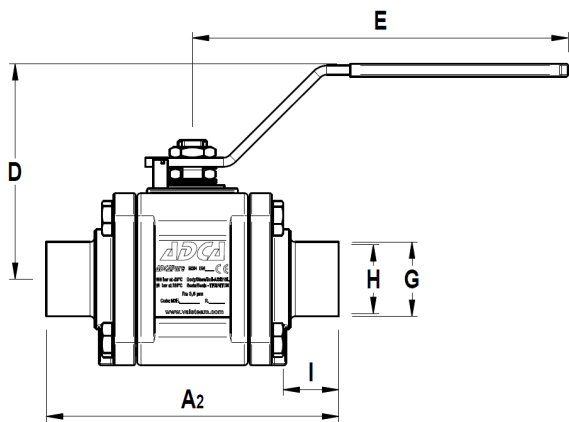
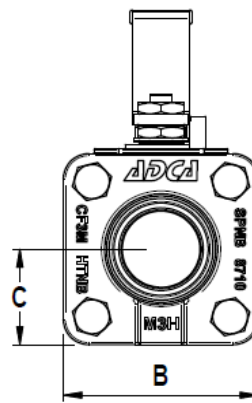
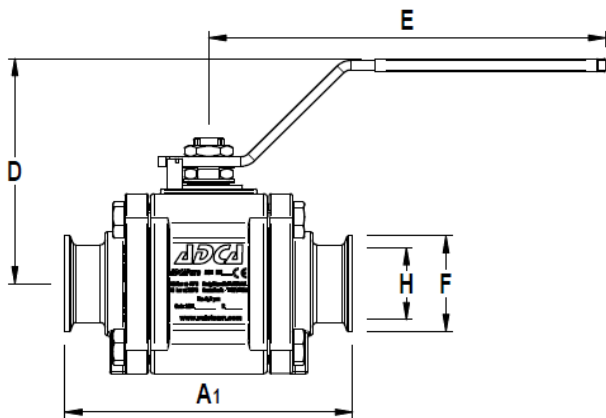

Tube weld easy and quick installation - standard

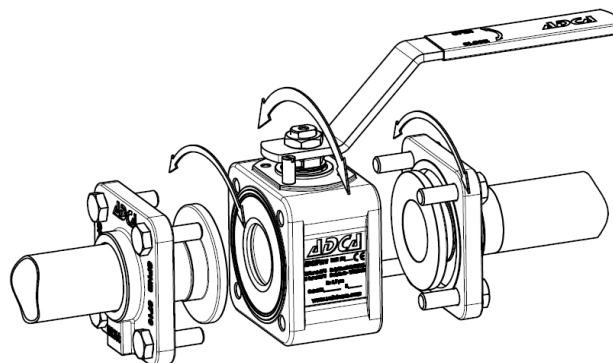

Loose body flanges make it possible to install the valve without the aligning of welded end connections. After installation the valve can rotate 360° for the desired orientation.

MATERIALS

POS. N°	DESIGNATION	MATERIAL
1	Valve body	CF3M / 1.4409
2	TC end connection	CF3M / 1.4409
3	Tube weld end connection	AISI 316L / 1.4404
4	** Flange	CF3M / 1.4409
5	Stem	AISI 316L / 1.4404
6	* Valve ball	AISI 316L / 1.4404
7	* Standard seat	TFM 1600
8	* Cavity filler seat	TFM 1600
9	* Body seal	PTFE
10	* Stem seals	TFM 1600
11	* Spacer	AISI 316 / 1.4401
12	Handle	AISI 304 / 1.4301
13	Handle end	Vinyl
14	* Spring washers	AISI 304 / 1.4301
15	Compression nut	AISI 304 / 1.4301
16	* Lock washer	AISI 304 / 1.4301
17	Fixing bolt	AISI 304 / 1.4301
18	Stop pin	AISI 304 / 1.4301
19	Antistatic device	AISI 316 / 1.4401
20	* O-ring	Viton

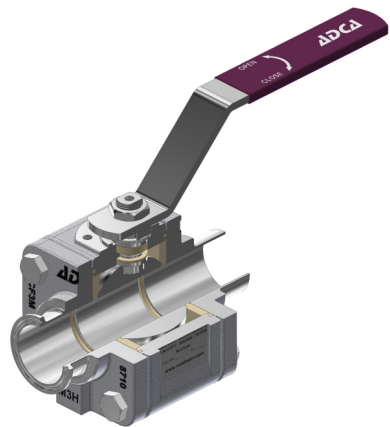
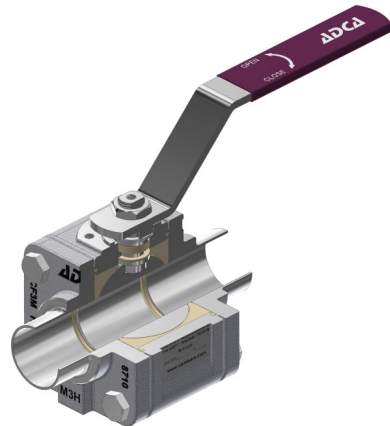

* Available spare parts;

** Loose flange. Allows a 360° rotation of the valve when using tube weld connections.

Remarks: FDA / USP Class VI seals certificate on request.

All valves have a serial number. In case of non-standard valves, this number must be supplied if spare parts are ordered.

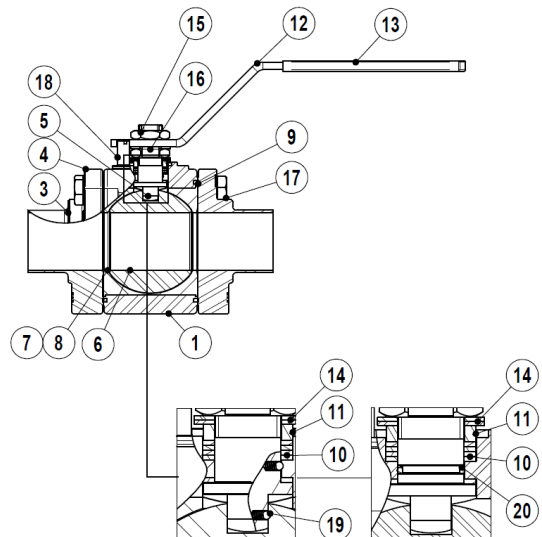
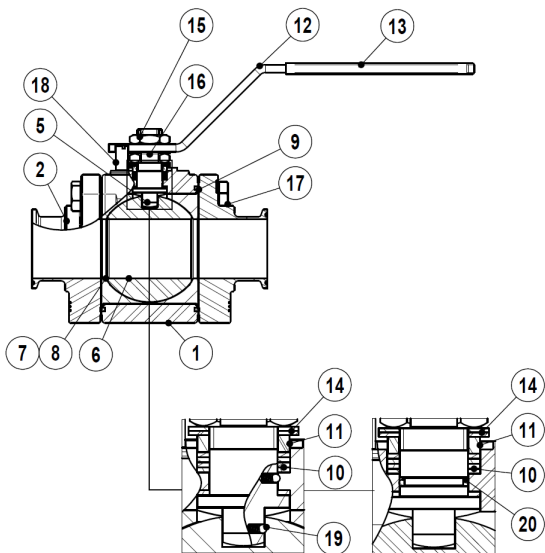

ORDERING CODES M3H											
Valve model	MH	X	X	X	F	X	X	CD	X	15	
M3H 3 pieces ball valve CF3M	MH										
Lever handle											
Flat lever handle stainless steel / plastic cover	X										
Flat lever handle stainless steel / plastic cover w/ lockable system	3										
Bare stem	9										
Material											
CF3M / 1.4409		X									
Seat design											
Standard seats				X							
Cavity fillers					F						
Seat material											
TFM 1600					F						
Surface finish (a)											
Standard surface finish						X					
Electropolished internal wetted parts (SF5)							E				
Special features											
None								X			
Oxygen cleaning									O		
End connections											
TC – Sanitary clamps DIN 32676										CD	
ETO – Extended tube orbital welding DIN 11850 (360° rotation design)											TD
TC / ETO – Combination DIN (360° rotation design)											CTD
Ball port											
True bore (standard)											X
Full bore											NA
Size											
DN 10											10
DN 15											15
DN 20											20
DN 25											25
DN 32											32
DN 40											40
DN 50											50
Special valves / Extras											
Full description or additional codes have to be added in case of a non standard combination											E

(a) Consult IS PV20.00 (Technical information) for further details and other surface finish options.
NA – Not available.

Алматы (7273)495-231
Ангарск (3955)60-70-56
Архангельск (8182)63-90-72
Астрахань (8512)99-46-04
Барнаул (3852)73-04-60
Белгород (4722)40-23-64
Благовещенск (4162)22-76-07
Брянск (4832)59-03-52
Владивосток (423)249-28-31
Владикавказ (8672)28-90-48
Владимир (4922)49-43-18
Волгоград (844)278-03-48
Вологда (8172)26-41-59
Воронеж (473)204-51-73
Екатеринбург (343)384-55-89

Иваново (4932)77-34-06
Ижевск (3412)26-03-58
Иркутск (395)279-98-46
Казань (843)206-01-48
Калининград (4012)72-03-81
Калуга (4842)92-23-67
Кемерово (3842)65-04-62
Киров (8332)68-02-04
Коломна (4966)23-41-49
Кострома (4942)77-07-48
Краснодар (861)203-40-90
Красноярск (391)204-63-61
Курск (4712)77-13-04
Курган (3522)50-90-47
Липецк (4742)52-20-81

Магнитогорск (3519)55-03-13
Москва (495)268-04-70
Мурманск (8152)59-64-93
Набережные Челны (8552)20-53-41
Нижний Новгород (831)429-08-12
Новокузнецк (3843)20-46-81
Ноябрьск (3496)41-32-12
Новосибирск (383)227-86-73
Омск (3812)21-46-40
Орел (4862)44-53-42
Оренбург (3532)37-68-04
Пенза (8412)22-31-16
Петрозаводск (8142)55-98-37
Псков (8112)59-10-37
Пермь (342)205-81-47

Ростов-на-Дону (863)308-18-15
Рязань (4912)46-61-64
Самара (846)206-03-16
Санкт-Петербург (812)309-46-40
Саратов (845)249-38-78
Севастополь (8692)22-31-93
Саранск (8342)22-96-24
Симферополь (3652)67-13-56
Смоленск (4812)29-41-54
Сочи (862)225-72-31
Ставрополь (8652)20-65-13
Сургут (3462)77-98-35
Сыктывкар (8212)25-95-17
Тамбов (4752)50-40-97
Тверь (4822)63-31-35

Тольятти (8482)63-91-07
Томск (3822)98-41-53
Тула (4872)33-79-87
Тюмень (3452)66-21-18
Ульяновск (8422)24-23-59
Улан-Удэ (3012)59-97-51
Уфа (347)229-48-12
Хабаровск (4212)92-98-04
Чебоксары (8352)28-53-07
Челябинск (351)202-03-61
Череповец (8202)49-02-64
Чита (3022)38-34-83
Якутск (4112)23-90-97
Ярославль (4852)69-52-93

Россия +7(495)268-04-70

Казахстан +7(7172)727-132

Киргизия +996(312)96-26-47