

Алматы (7273)495-231
Ангарск (3955)60-70-56
Архангельск (8182)63-90-72
Астрахань (8512)99-46-04
Барнаул (3852)73-04-60
Белгород (4722)40-23-64
Благовещенск (4162)22-76-07
Брянск (4832)59-03-52
Владивосток (423)249-28-31
Владикавказ (8672)28-90-48
Владимир (4922)49-43-18
Волгоград (844)278-03-48
Вологда (8172)26-41-59
Воронеж (473)204-51-73
Екатеринбург (343)384-55-89

Иваново (4932)77-34-06
Ижевск (3412)26-03-58
Иркутск (395)279-98-46
Казань (843)206-01-48
Калининград (4012)72-03-81
Калуга (4842)92-23-67
Кемерово (3842)65-04-62
Киров (8332)68-02-04
Коломна (4966)23-41-49
Кострома (4942)77-07-48
Краснодар (861)203-40-90
Красноярск (391)204-63-61
Курск (4712)77-13-04
Курган (3522)50-90-47
Липецк (4742)52-20-81

Магнитогорск (3519)55-03-13
Москва (495)268-04-70
Мурманск (8152)59-64-93
Набережные Челны (8552)20-53-41
Нижний Новгород (831)429-08-12
Новокузнецк (3843)20-46-81
Ноябрьск (3496)41-32-12
Новосибирск (383)227-86-73
Омск (3812)21-46-40
Орел (4862)44-53-42
Оренбург (3532)37-68-04
Пенза (8412)22-31-16
Петрозаводск (8142)55-98-37
Псков (8112)59-10-37
Пермь (342)205-81-47

Ростов-на-Дону (863)308-18-15
Рязань (4912)46-61-64
Самара (846)206-03-16
Санкт-Петербург (812)309-46-40
Саратов (845)249-38-78
Севастополь (8692)22-31-93
Саранск (8342)22-96-24
Симферополь (3652)67-13-56
Смоленск (4812)29-41-54
Сочи (862)225-72-31
Ставрополь (8652)20-65-13
Сургут (3462)77-98-35
Сыктывкар (8212)25-95-17
Тамбов (4752)50-40-97
Тверь (4822)63-31-35

Тольятти (8482)63-91-07
Томск (3822)98-41-53
Тула (4872)33-79-87
Тюмень (3452)66-21-18
Ульяновск (8422)24-23-59
Улан-Удэ (3012)59-97-51
Уфа (347)229-48-12
Хабаровск (4212)92-98-04
Чебоксары (8352)28-53-07
Челябинск (351)202-03-61
Череповец (8202)49-02-64
Чита (3022)38-34-83
Якутск (4112)23-90-97
Ярославль (4852)69-52-93

Россия +7(495)268-04-70

Казахстан +7(7172)727-132

Киргизия +996(312)96-26-47

<https://adca.nt-rt.ru/> || acd@nt-rt.ru



STEAM DISTRIBUTION MANIFOLD MAS



STEAM DISTRIBUTION MANIFOLD MAS

DESCRIPTION

The MAS series steam distribution manifolds are essentially designed to allow the placement of steam supply valves in a single location, reducing costs and providing an easy control of different steam lines.

The drain connection, with an automatic steam trap installed, discharges any condensate formed, thus providing high quality dry steam.

MAIN FEATURES

Several installation possibilities.

Reduced field assembly costs, achieved by means of prefabrication.

OPTIONS: Complete units including valves, pressure gauges and steam trap station.
Different designs.

USE: Saturated or superheated steam.
Water, compressed air and other fluids (on request).

AVAILABLE

MODELS: MAS-H – horizontal steam distribution manifold.
MAS-WH – horizontal liquid manifold.
MAS-GH – horizontal gas manifold.

SIZES: 4" to 12"; DN 100 to DN 300.

CONNECTIONS: Flanged EN 1092-1 PN 16 or PN 40.
Flanged ASME B16.5 Class 150 or 300.
Female threaded ISO 7 Rp or NPT (on request).

INSTALLATION: Always with the condensate connection pointing downwards.
See IMI – Installation and maintenance instructions.

INQUIRY

INFORMATION: Type of fluid, maximum operating pressure and temperature.
Manifold diameter (dimension B).
Number of connections from left to right using suffix "I" and "O" to identify the inlets and outlets.
Example: MAS-H B-168 with 1 DN100-I + 2 DN50-O + 1 DN40-O.
Condensate connection (dimension d1).
Other relevant information like insulation thickness, instrumentation connections, etc.
Note: In case of order, an approval drawing shall be sent before manufacturing.



CE MARKING – GROUP 2 (PED – European Directive)

Since this is not a standard product, and can have different volumes and operation conditions, the conformity assessment and CE marking has to be carried out case by case.

Design code: AD Merkblatt.

MATERIALS	
DESIGNATION	MATERIAL
Body	P235GH / 1.0325
Heads	P265GH / 1.0425
Inlet / Outlet pipes	P235GH / 1.0325
EN flanges	P250GH / 1.0460
ASME flanges	ASTM A105 / 1.0432
Sockets	ASTM A105 / 1.0432
* Internals	S235JR / 1.0038

* If any.

FLANGE CONNECTIONS			
RATING	SIZE	EN	ASME
PN 16	DN 15 to DN 50 *	EN 1092-1 PN 40	ASME B16.5 Cl. 150
PN 16	DN 65 to DN 300	EN 1092-1 PN 16	ASME B16.5 Cl. 150
PN 25	DN 15 to DN 150	EN 1092-1 PN 40	ASME B16.5 Cl. 300
PN 25	DN 200 to DN 300	EN 1092-1 PN 25	ASME B16.5 Cl. 300
PN 40	DN 15 to DN 300	EN 1092-1 PN 40	ASME B16.5 Cl. 300

* Flanges EN 1092-1 PN 16 and PN 40, from DN 15 to DN 50, have the same number and size of holes.

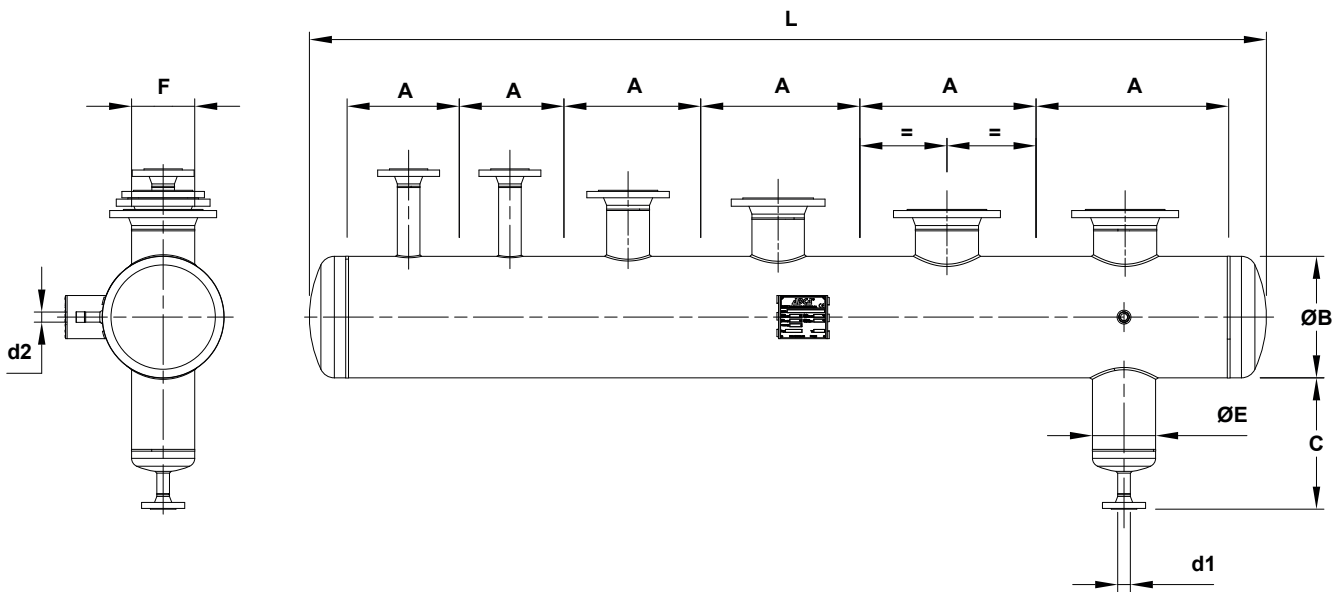

SUGGESTED DIMENSIONS (mm) *														
SIZE	1/2" DN 15	3/4" DN 20	1" DN 25	1 1/4" DN 32	1 1/2" DN 40	2" DN 50	2 1/2" DN 65	3" DN 80	4" DN 100	5" DN 125	6" DN 150	8" DN 200	10" DN 250	12" DN 300
A	200	200	200	235	235	270	270	360	360	425	475	575	675	675

* Recommended minimum gap between flanged connections for later assembly of EN 1092-1 PN 16 / PN 40 flanged globe valves.

Remark: Since this is not a standard product, and can have different volumes and sizes, the certified values for each dimension will be supplied only after complete data evaluation and order confirmation.

MAXIMUM BRANCH CONNECTIONS SIZE "F" ACCORDING TO MANIFOLD DIAMETER "B"							
$\varnothing B$ (mm)	114	140	168	220	275	325	357
F	$\leq 2 1/2"$ $\leq DN 65$	$\leq 3"$ $\leq DN 80$	$\leq 4"$ $\leq DN 100$	$\leq 6"$ $\leq DN 150$	$\leq 8"$ $\leq DN 200$	$\leq 8"$ $\leq DN 200$	$\leq 10"$ $\leq DN 250$

TYPICAL INSTALLATIONS

MATERIALS	
POS. N°	DESIGNATION
1	MAS-H Manifold
2	BM32 Bimetallic steam trap
3	VF20 Bellow seal valve
5	DW40S Sight glass
6	RD40 Check valve
7	GSC-40 Gauge siphon
8	GC400 Gauge cock
9	MAN-100 Pressure gauge

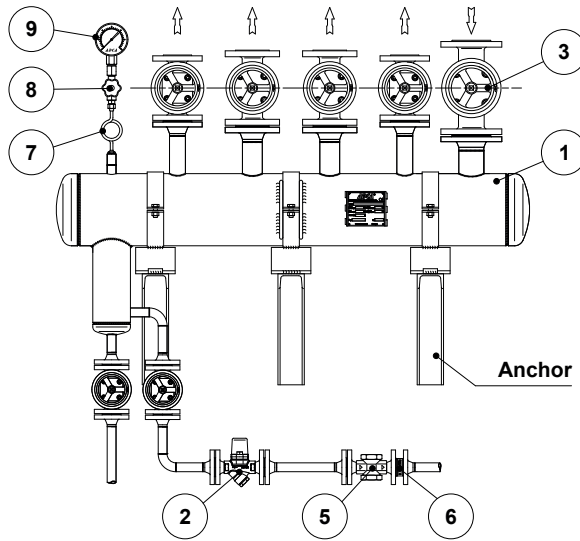

MATERIALS	
POS. N°	DESIGNATION
1	MAS-H Manifold
2	IB12 Inverted bucket trap
3	VF20 Bellow seal valve
4	GV32B Globe valve
5	SW12 Sight glass
6	RT25 Check valve
7	GSU-40 Gauge siphon
8	GC400 Gauge cock
9	MAN-100 Pressure gauge

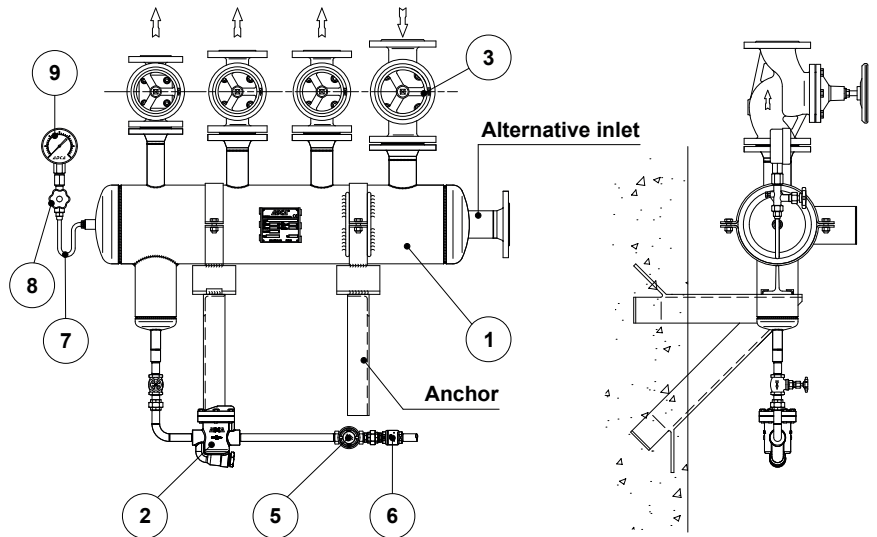

MATERIALS	
POS. N°	DESIGNATION
1	MAS-H Manifold
2	FLT20 Float steam trap *
3	VF20 Bellow seal valve
4	GV32B Globe valve
5	SCKi Sight checker
6	IS16F Y strainer
7	GSU-40 Gauge siphon
8	GC400 Gauge cock
9	MAN-100 Pressure gauge

*Recommended for low pressures only.

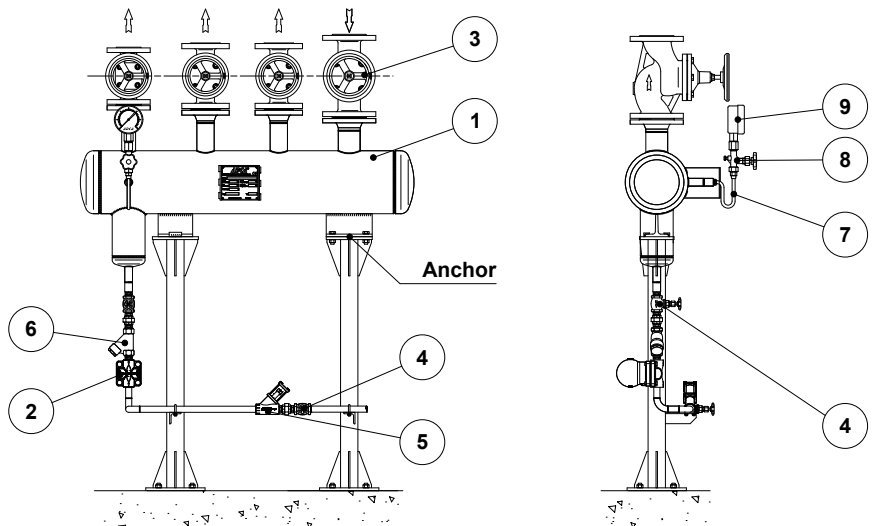

Алматы (7273)495-231
Ангарск (3955)60-70-56
Архангельск (8182)63-90-72
Астрахань (8512)99-46-04
Барнаул (3852)73-04-60
Белгород (4722)40-23-64
Благовещенск (4162)22-76-07
Брянск (4832)59-03-52
Владивосток (423)249-28-31
Владикавказ (8672)28-90-48
Владимир (4922)49-43-18
Волгоград (844)278-03-48
Вологда (8172)26-41-59
Воронеж (473)204-51-73
Екатеринбург (343)384-55-89

Иваново (4932)77-34-06
Ижевск (3412)26-03-58
Иркутск (395)279-98-46
Казань (843)206-01-48
Калининград (4012)72-03-81
Калуга (4842)92-23-67
Кемерово (3842)65-04-62
Киров (8332)68-02-04
Коломна (4966)23-41-49
Кострома (4942)77-07-48
Краснодар (861)203-40-90
Красноярск (391)204-63-61
Курск (4712)77-13-04
Курган (3522)50-90-47
Липецк (4742)52-20-81

Магнитогорск (3519)55-03-13
Москва (495)268-04-70
Мурманск (8152)59-64-93
Набережные Челны (8552)20-53-41
Нижний Новгород (831)429-08-12
Новокузнецк (3843)20-46-81
Ноябрьск (3496)41-32-12
Новосибирск (383)227-86-73
Омск (3812)21-46-40
Орел (4862)44-53-42
Оренбург (3532)37-68-04
Пенза (8412)22-31-16
Петрозаводск (8142)55-98-37
Псков (8112)59-10-37
Пермь (342)205-81-47

Ростов-на-Дону (863)308-18-15
Рязань (4912)46-61-64
Самара (846)206-03-16
Санкт-Петербург (812)309-46-40
Саратов (845)249-38-78
Севастополь (8692)22-31-93
Саранск (8342)22-96-24
Симферополь (3652)67-13-56
Смоленск (4812)29-41-54
Сочи (862)225-72-31
Ставрополь (8652)20-65-13
Сургут (3462)77-98-35
Сыктывкар (8212)25-95-17
Тамбов (4752)50-40-97
Тверь (4822)63-31-35

Тольятти (8482)63-91-07
Томск (3822)98-41-53
Тула (4872)33-79-87
Тюмень (3452)66-21-18
Ульяновск (8422)24-23-59
Улан-Удэ (3012)59-97-51
Уфа (347)229-48-12
Хабаровск (4212)92-98-04
Чебоксары (8352)28-53-07
Челябинск (351)202-03-61
Череповец (8202)49-02-64
Чита (3022)38-34-83
Якутск (4112)23-90-97
Ярославль (4852)69-52-93

Россия +7(495)268-04-70

Казахстан +7(7172)727-132

Киргизия +996(312)96-26-47

<https://adca.nt-rt.ru/> || acd@nt-rt.ru