

Алматы (7273)495-231
Ангарск (3955)60-70-56
Архангельск (8182)63-90-72
Астрахань (8512)99-46-04
Барнаул (3852)73-04-60
Белгород (4722)40-23-64
Благовещенск (4162)22-76-07
Брянск (4832)59-03-52
Владивосток (423)249-28-31
Владикавказ (8672)28-90-48
Владимир (4922)49-43-18
Волгоград (844)278-03-48
Вологда (8172)26-41-59
Воронеж (473)204-51-73
Екатеринбург (343)384-55-89

Иваново (4932)77-34-06
Ижевск (3412)26-03-58
Иркутск (395)279-98-46
Казань (843)206-01-48
Калининград (4012)72-03-81
Калуга (4842)92-23-67
Кемерово (3842)65-04-62
Киров (8332)68-02-04
Коломна (4966)23-41-49
Кострома (4942)77-07-48
Краснодар (861)203-40-90
Красноярск (391)204-63-61
Курск (4712)77-13-04
Курган (3522)50-90-47
Липецк (4742)52-20-81

Магнитогорск (3519)55-03-13
Москва (495)268-04-70
Мурманск (8152)59-64-93
Набережные Челны (8552)20-53-41
Нижний Новгород (831)429-08-12
Новокузнецк (3843)20-46-81
Ноябрьск (3496)41-32-12
Новосибирск (383)227-86-73
Омск (3812)21-46-40
Орел (4862)44-53-42
Оренбург (3532)37-68-04
Пенза (8412)22-31-16
Петрозаводск (8142)55-98-37
Псков (8112)59-10-37
Пермь (342)205-81-47

Ростов-на-Дону (863)308-18-15
Рязань (4912)46-61-64
Самара (846)206-03-16
Санкт-Петербург (812)309-46-40
Саратов (845)249-38-78
Севастополь (8692)22-31-93
Саранск (8342)22-96-24
Симферополь (3652)67-13-56
Смоленск (4812)29-41-54
Сочи (862)225-72-31
Ставрополь (8652)20-65-13
Сургут (3462)77-98-35
Сыктывкар (8212)25-95-17
Тамбов (4752)50-40-97
Тверь (4822)63-31-35

Тольятти (8482)63-91-07
Томск (3822)98-41-53
Тула (4872)33-79-87
Тюмень (3452)66-21-18
Ульяновск (8422)24-23-59
Улан-Удэ (3012)59-97-51
Уфа (347)229-48-12
Хабаровск (4212)92-98-04
Чебоксары (8352)28-53-07
Челябинск (351)202-03-61
Череповец (8202)49-02-64
Чита (3022)38-34-83
Якутск (4112)23-90-97
Ярославль (4852)69-52-93

Россия +7(495)268-04-70

Казахстан +7(7172)727-132

Киргизия +996(312)96-26-47

<https://adca.nt-rt.ru/> || acd@nt-rt.ru



PRESSURE OPERATED PUMP POP-LC



PRESSURE OPERATED PUMP POP-LC

The ADCAMat POP-LC low capacity pressure operated pump is recommended in the transfer of steam condensate, oils and other non-hazardous liquids compatible with the construction, to a higher elevation or pressure.

Under certain conditions, it can drain a closed vessel under vacuum or pressure. The pump can be operated using steam, compressed air or other gases, and is manufactured in carbon steel or stainless steel.

OPERATION

Liquid flows by gravity into the pump through an inlet check valve, lifting the float. At this point, the motive fluid intake valve is closed while the vent valve is open. As the float reaches its highest position the motive fluid intake valve opens and the vent valve closes, allowing the motive fluid to enter the pump body. The pressure in the pump builds up just enough to overcome backpressure.

The pressurized liquid opens the outlet check valve and the discharge starts. The liquid discharged may be quantified through a special counter, enabling the pump to function as a reliable flow meter.

When the float reaches its lower position the motive fluid intake valve closes and the vent valve opens allowing the liquid to fill the pump once again, repeating the cycle.

MAIN FEATURES

- Compact design.
- Hardened stainless steel wear parts.
- High-endurance inconel springs.
- Low filling head to minimize installation space.
- No electric requirements or NPSH issues.
- Suitable for hazardous environments.
- Low running costs.
- Pump mechanism with 360° rotation (limited to flange bolt holes).

OPTIONS: Level gauge.
Stroke counter.

USE: To lift steam condensate and other liquids compatible with the construction.

AVAILABLE MODELS: POP-LCS – carbon steel.
POP-LCSS – stainless steel.

SIZES: 1" x 1", 1 1/2" x 1", 1 1/2" x 1 1/2".
DN 25 x 25, DN 40 x 25 and DN 40 x 40.

CONNECTIONS: Flanged EN 1092-1 PN 16.
Flanged ASME B16.5 Class 150.
Female threaded ISO 7 Rp (threaded flanges).
Others on request.

INSTALLATION: Horizontal installation. An example is shown in Fig. 1. See IMI – Installation and maintenance instructions.

MOTIVE MEDIUM: Saturated steam, compressed air, nitrogen and other gases.



BODY LIMITING CONDITIONS *					
POP-LCS			POP-LCSS		
	ALLOW. PRESS.	RELAT. TEMP.		ALLOW. PRESS.	RELAT. TEMP.
PN 16	16 bar	50 °C	PN 16	16 bar	50 °C
	14 bar	100 °C		15 bar	100 °C
	13 bar	195 °C		12,7 bar	200 °C
	12 bar	250 °C		12 bar	250 °C
CLASS 150	16 bar	50 °C	CLASS 150	15,3 bar	50 °C
	14 bar	100 °C		13,3 bar	100 °C
	13 bar	195 °C		11,1 bar	200 °C
	12 bar	250 °C		10,2 bar	250 °C

* Rating according to EN 1092-1:2018.

CE MARKING – GROUP 2 (PED – European Directive)	
PN 16	Category
All sizes	2 (CE marked)

LIMITING CONDITIONS

Liquid specific gravity	0,8 to 1
Maximum viscosity	5 °Engler
Maximum motive inlet pressure	10 bar
Minimum motive inlet pressure	0,5 bar
Maximum operating temperature	185 °C
Minimum operating temperature *	0 °C
Pump discharge per cycle	11,2 L

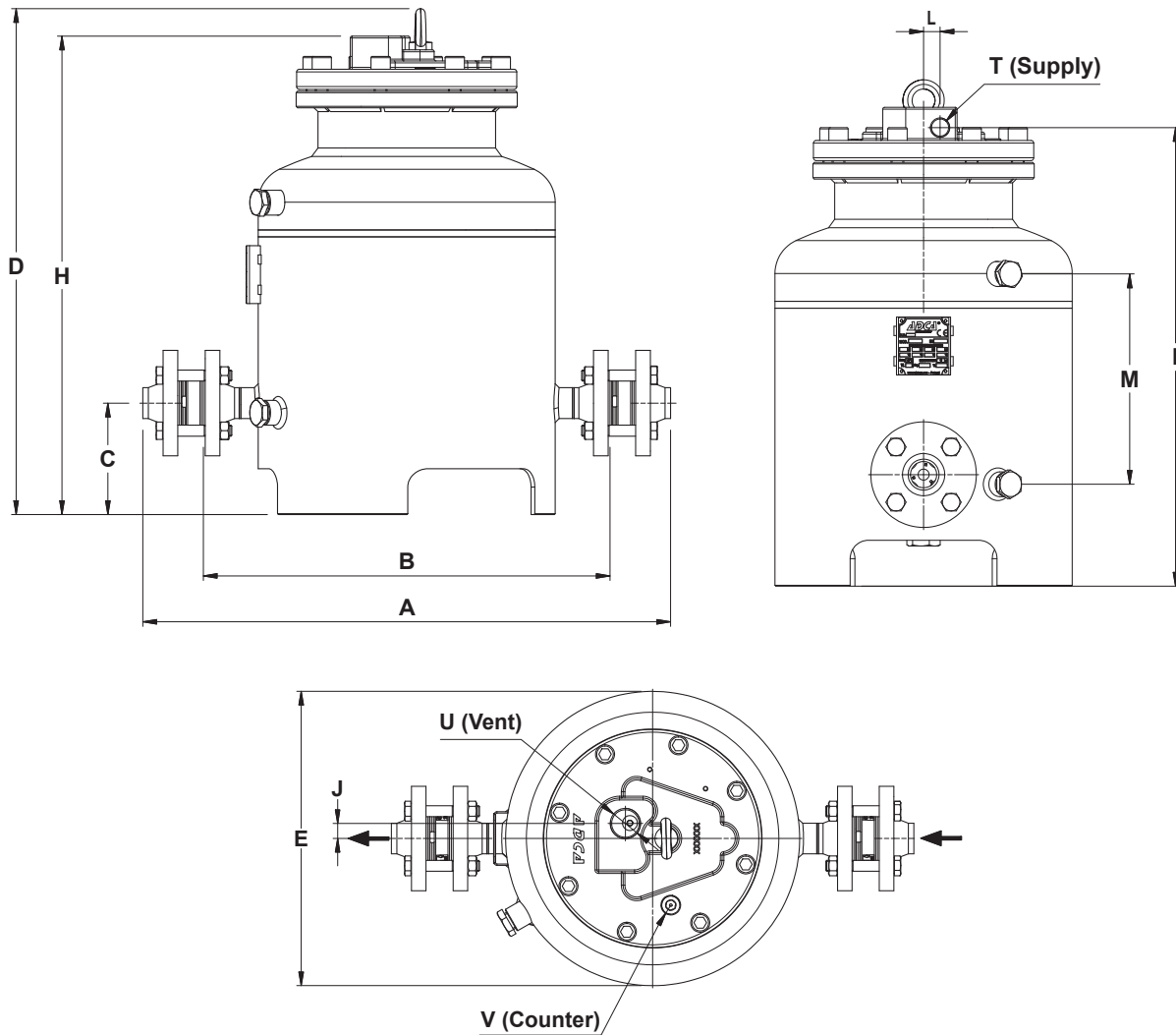

DIMENSIONS (mm)

SIZE	A *	B *	C	D	E	H	I	J	L	M	T **	U **	V **	WGT. (kg)	VOL. (L)
1" x 1" DN 25 x 25	578	444	122	552	323	522	500	17	18	229	1/2"	1"	1/2"	60	25,7
1 1/2" x 1" DN 40 x 25	597	449	122	552	323	522	500	17	18	229	1/2"	1"	1/2"	60	25,7
1 1/2" x 1 1/2" DN 40 x 40	615	454	122	552	323	522	500	17	18	229	1/2"	1"	1/2"	61	25,7

* With EN 1092-1 welding neck flanges. Dimensions may differ if ASME B16.5 flanges or ISO 7 Rp female threaded flanges are requested. Consult the manufacturer.

** As standard, in versions manufactured with EN 1092-1 PN 16 flanges, these connections are female threaded ISO 7 Rp. In versions with ASME B16.5 flanges, these connections are female threaded NPT.

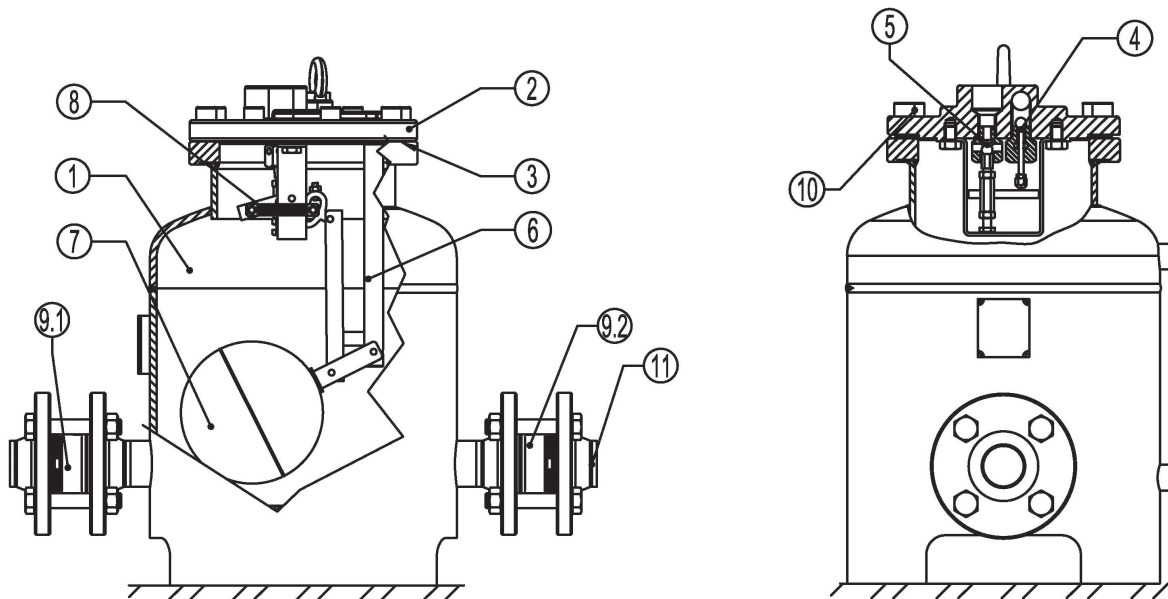

MATERIALS			
POS. N°	DESIGNATION	POP-LCS	POP-LCSS
1	Pump body	P265GH / 1.0425; P235GH / 1.0345; S235JR / 1.0038	AISI 316 / 1.4401; AISI 316L / 1.4404
2	Cover	GJS-400-15 / 0.7040	CF8M / 1.4408
3	* Cover gasket	Stainless steel / Graphite	Stainless steel / Graphite
4	* Intake valve/seat assembly	Stainless steel	Stainless steel
5	* Exhaust valve/seat assembly	Stainless steel	Stainless steel
6	Internal mechanism	Stainless steel	Stainless steel
7	* Float	Stainless steel	Stainless steel
8	* Spring assembly (2 pcs.)	Inconel	Inconel
9.1	* Outlet check valve	CF8M / 1.4408	CF8M / 1.4408
9.2	* Inlet check valve	CF8M / 1.4408	CF8M / 1.4408
10	Bolts	Steel 8.8	Stainless steel A2-70
11	Counter flanges	P250GH / 1.0460	AISI 316 / 1.4401

* Available spare parts.

STROKE COUNTER

A stroke counter can be screwed onto a respective female threaded connection on the pump cover. Mechanical and digital versions are available. The mechanical version requires that the following conditions are met.

LIMITING CONDITIONS *	
Minimum motive pressure (steam)	6 bar
Minimum motive pressure (compressed air and nitrogen)	5 bar
Minimum system backpressure (steam)	700 mbar *
Minimum system backpressure (compressed air and nitrogen)	700 mbar *

* The pump outlet check valve can be supplied with a stronger spring to simulate increased system backpressure. Consult manufacturer.

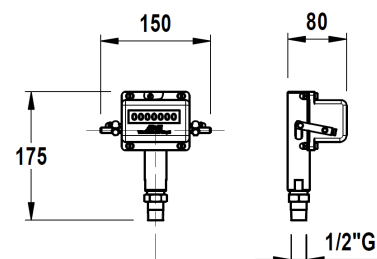

The digital version is composed of sensor and remote stroke counter. The device can be tailor made to meet customer requirements and is not dependent on the process condition. The standard unit is battery powered, features an LCD display and optional volt-free output connection for remote monitorization. Consult manufacturer.

SIZING

To accurately size a pressure operated pump, the following information must be provided:

1. The condensate load (kg/h).
2. The operating medium (steam, compressed air or other gases) and its pressure.
3. The total lift or backpressure in bar the pump will have to overcome. This includes the change in fluid level elevation after the pump (0.0981 bar/m of lift), plus pressure in the return piping, plus the pressure drop caused by pipe friction and other system components.
4. Available filling head (see Fig. 1) in mm or any other dimension that allows its determination.

MATERIALS			
POS. N°	DESIGNATION	POS. N°	DESIGNATION
2	Receiver	5	Pump
3	Ball valve	6	Disc check valve
4	Y strainer	7	Steam trap

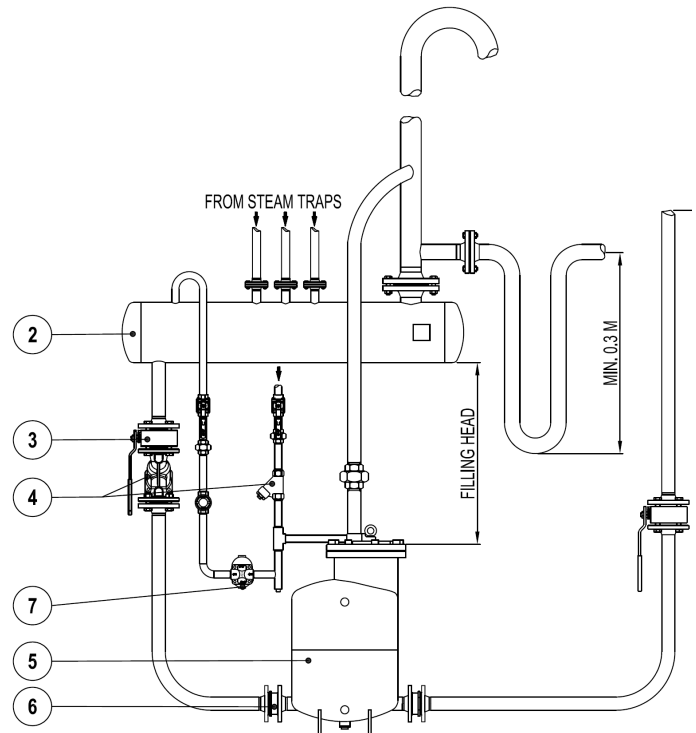

Fig. 1

CAPACITY CORRECTION FACTOR FOR GASES OTHER THAN STEAM					
% Backpressure vs Motive pressure (BP/MP)	10%	30%	50%	70%	90%
Correction factor	1,04	1,08	1,12	1,18	1,28

Table 1

CAPACITY CORRECTION FACTORS FOR FILLING HEADS OTHER THAN 300 mm				
PUMP SIZE	FILLING HEAD (mm)			
	150	300	600	900
1" x 1" DN 25 x 25	0,7	1	1,2	1,35
1 1/2" x 1" DN 40 x 25	0,7	1	1,2	1,35
1 1/2" x 1 1/2" DN 40 x 40	0,7	1	1,2	1,35

Table 2

RECEIVER

A receiver is recommended to temporarily hold the liquid and prevent any flooding of the equipment, while the pump is performing a pumping cycle. A definable length of large diameter pipe can be used.

Suggested receiver sizes are shown in Table 3.

RECEIVER			
PUMP SIZE	1" x 1" DN 25 x 25	1 1/2" x 1" DN 40 x 25	1 1/2" x 1 1/2" DN 40 x 40
Pipe size with 1 m lenght	6"		

Table 3

FLOW RATE (kg/h) INSTALLATION WITH 300 mm FILLING HEAD ABOVE THE PUMP COVER			
MOTIVE PRESSURE (bar)	TOTAL LIFT (bar)	1" x 1" DN 25 x 25	1 1/2" x 1" and 1 1/2" x 1 1/2" DN 40 x 25 and DN 40 x 40
1	0,35	820	1260
2		1050	1540
3		1100	1750
4		1150	1860
5		1210	1970
6		1250	2160
8		1290	2180
10		1300	2195
2	1	800	1200
3		940	1430
4		1080	1590
5		1110	1660
6		1140	1730
8		1180	1820
10		1200	1880
3	2	790	1100
4		900	1520
5		1000	1580
6		1140	1690
8		1200	1785
10	1220	1820	
4	3	750	1000
5		860	1310
6		910	1450
8		970	1540
10		980	1580
5	4	730	960
6		840	1310
8		920	1410
10		940	1500
6	5	710	890
8		770	1040
10		880	1150
7	6	730	840
8		790	980
10		880	1090

Table 4 (based on liquid specific gravity of 0,9 to 1,0)

Example

Condensate load	950 kg/h
Filling head	150 mm
Motive fluid	Compressed air
Available pressure	8 bar
Vertical lift after pump	10 m
Return piping pressure	1,2 bar
Piping friction pressure drop	Negligible

Filling head correction:
With 150 mm filling head the correction factor from Table 2 is 0,7. The corrected capacity is thus 1540 kg/h x 0,7 = 1078 kg/h.

Calculations:

Total backpressure: 1,2 bar + (10 m x 0,0981) = 2,181 bar.
Assuming steam as motive medium at a pressure of 8 bar and a total backpressure of 3 bar, then according to Table 4 a DN 40 pump, with a capacity of 1540 kg/h, is the recommended size.

Correction for air as a motive medium:

The % backpressure is 2,181 bar / 8 bar = 27%.
The correction factor from Table 1 is 1,08.
The corrected capacity is thus 1078 kg/h x 1,08 = 1164,2 kg/h, and so, a DN 40 pump is still the recommended size.

TYPICAL APPLICATIONS

CONDENSATE RECOVERY IN A OPEN LOOP SYSTEM

The pump transfers high temperature condensate without cavitation problems.

The vent line must be unrestricted and self draining to the receiver.

MATERIALS			
POS. N°	DESIGNATION	POS. N°	DESIGNATION
1	Heat exchanger	5	Pump
2	Receiver	6	Disc check valve
3	Ball valve	7	Steam trap
4	Y strainer	8	Air vent

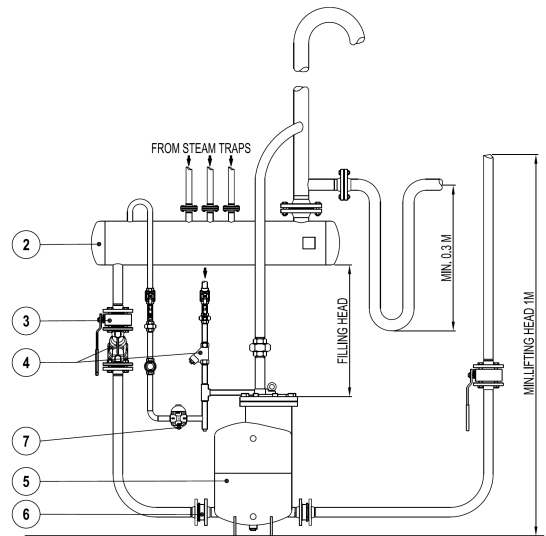

REMOVAL OF CONDENSATE UNDER PRESSURE WITH PUMP AND STEAM TRAP COMBINATION

The pump is installed in a closed loop with its vent connected to a pressurized receiver.

When steam pressure is sufficient to overcome backpressure, the steam trap operates. As soon as, e.g., the equipment's control valve starts to modulate, the steam pressure will decrease (even vacuum can occur). The lower differential pressure decreases the steam trap ability to discharge, causing the condensate level to rise inside the body of the pump. Once the pump float reaches its higher position, the intake valve opens and steam replaces the necessary positive pressure to pump out the condensate.

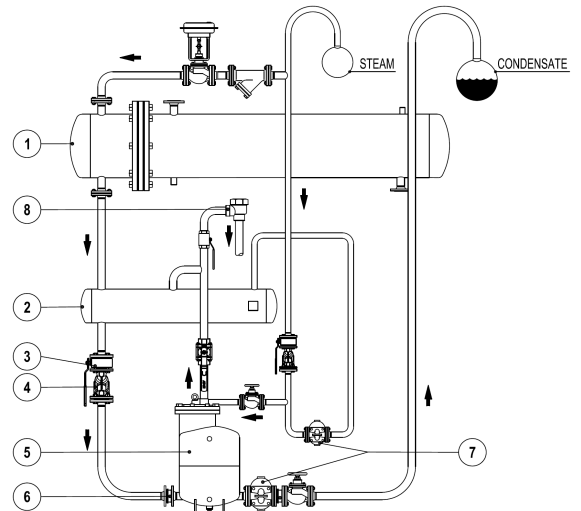

DRAINAGE OF A SINGLE UNIT UNDER VACUUM

This configuration works with units operating with a minimum absolute pressure of 0,2 bar.

For proper operation the filling head (H1) must range between 1 and 2 meters. The lift (H) must be as minimum as possible, but never less than 1 meter, otherwise a siphon with height (H2) is required.

Steam must be used as motive medium, and its maximum pressure should not exceed 3 bar.

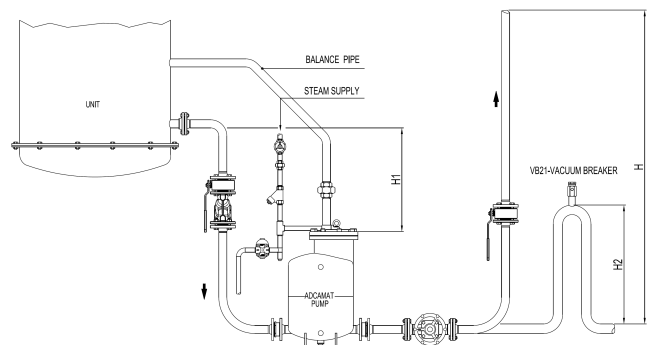

Алматы (7273)495-231
Ангарск (3955)60-70-56
Архангельск (8182)63-90-72
Астрахань (8512)99-46-04
Барнаул (3852)73-04-60
Белгород (4722)40-23-64
Благовещенск (4162)22-76-07
Брянск (4832)59-03-52
Владивосток (423)249-28-31
Владикавказ (8672)28-90-48
Владимир (4922)49-43-18
Волгоград (844)278-03-48
Вологда (8172)26-41-59
Воронеж (473)204-51-73
Екатеринбург (343)384-55-89

Иваново (4932)77-34-06
Ижевск (3412)26-03-58
Иркутск (395)279-98-46
Казань (843)206-01-48
Калининград (4012)72-03-81
Калуга (4842)92-23-67
Кемерово (3842)65-04-62
Киров (8332)68-02-04
Коломна (4966)23-41-49
Кострома (4942)77-07-48
Краснодар (861)203-40-90
Красноярск (391)204-63-61
Курск (4712)77-13-04
Курган (3522)50-90-47
Липецк (4742)52-20-81

Магнитогорск (3519)55-03-13
Москва (495)268-04-70
Мурманск (8152)59-64-93
Набережные Челны (8552)20-53-41
Нижний Новгород (831)429-08-12
Новокузнецк (3843)20-46-81
Ноябрьск (3496)41-32-12
Новосибирск (383)227-86-73
Омск (3812)21-46-40
Орел (4862)44-53-42
Оренбург (3532)37-68-04
Пенза (8412)22-31-16
Петрозаводск (8142)55-98-37
Псков (8112)59-10-37
Пермь (342)205-81-47

Ростов-на-Дону (863)308-18-15
Рязань (4912)46-61-64
Самара (846)206-03-16
Санкт-Петербург (812)309-46-40
Саратов (845)249-38-78
Севастополь (8692)22-31-93
Саранск (8342)22-96-24
Симферополь (3652)67-13-56
Смоленск (4812)29-41-54
Сочи (862)225-72-31
Ставрополь (8652)20-65-13
Сургут (3462)77-98-35
Сыктывкар (8212)25-95-17
Тамбов (4752)50-40-97
Тверь (4822)63-31-35

Тольятти (8482)63-91-07
Томск (3822)98-41-53
Тула (4872)33-79-87
Тюмень (3452)66-21-18
Ульяновск (8422)24-23-59
Улан-Удэ (3012)59-97-51
Уфа (347)229-48-12
Хабаровск (4212)92-98-04
Чебоксары (8352)28-53-07
Челябинск (351)202-03-61
Череповец (8202)49-02-64
Чита (3022)38-34-83
Якутск (4112)23-90-97
Ярославль (4852)69-52-93

Россия +7(495)268-04-70

Казахстан +7(7172)727-132

Киргизия +996(312)96-26-47