

Алматы (7273)495-231
Ангарск (3955)60-70-56
Архангельск (8182)63-90-72
Астрахань (8512)99-46-04
Барнаул (3852)73-04-60
Белгород (4722)40-23-64
Благовещенск (4162)22-76-07
Брянск (4832)59-03-52
Владивосток (423)249-28-31
Владикавказ (8672)28-90-48
Владимир (4922)49-43-18
Волгоград (844)278-03-48
Вологда (8172)26-41-59
Воронеж (473)204-51-73
Екатеринбург (343)384-55-89

Иваново (4932)77-34-06
Ижевск (3412)26-03-58
Иркутск (395)279-98-46
Казань (843)206-01-48
Калининград (4012)72-03-81
Калуга (4842)92-23-67
Кемерово (3842)65-04-62
Киров (8332)68-02-04
Коломна (4966)23-41-49
Кострома (4942)77-07-48
Краснодар (861)203-40-90
Красноярск (391)204-63-61
Курск (4712)77-13-04
Курган (3522)50-90-47
Липецк (4742)52-20-81

Магнитогорск (3519)55-03-13
Москва (495)268-04-70
Мурманск (8152)59-64-93
Набережные Челны (8552)20-53-41
Нижний Новгород (831)429-08-12
Новокузнецк (3843)20-46-81
Ноябрьск (3496)41-32-12
Новосибирск (383)227-86-73
Омск (3812)21-46-40
Орел (4862)44-53-42
Оренбург (3532)37-68-04
Пенза (8412)22-31-16
Петрозаводск (8142)55-98-37
Псков (8112)59-10-37
Пермь (342)205-81-47

Ростов-на-Дону (863)308-18-15
Рязань (4912)46-61-64
Самара (846)206-03-16
Санкт-Петербург (812)309-46-40
Саратов (845)249-38-78
Севастополь (8692)22-31-93
Саранск (8342)22-96-24
Симферополь (3652)67-13-56
Смоленск (4812)29-41-54
Сочи (862)225-72-31
Ставрополь (8652)20-65-13
Сургут (3462)77-98-35
Сыктывкар (8212)25-95-17
Тамбов (4752)50-40-97
Тверь (4822)63-31-35

Тольятти (8482)63-91-07
Томск (3822)98-41-53
Тула (4872)33-79-87
Тюмень (3452)66-21-18
Ульяновск (8422)24-23-59
Улан-Удэ (3012)59-97-51
Уфа (347)229-48-12
Хабаровск (4212)92-98-04
Чебоксары (8352)28-53-07
Челябинск (351)202-03-61
Череповец (8202)49-02-64
Чита (3022)38-34-83
Якутск (4112)23-90-97
Ярославль (4852)69-52-93

Россия +7(495)268-04-70

Казахстан +7(7172)727-132

Киргизия +996(312)96-26-47

<https://adca.nt-rt.ru/> || acd@nt-rt.ru



PRESSURE OPERATED PUMP PPA14



PRESSURE OPERATED PUMP PPA14

DESCRIPTION

The ADCAMat PPA14 pressure operated pump is recommended in the transfer of steam condensate, oils and other non-hazardous liquids compatible with the construction, to a higher elevation or pressure. Under certain conditions, it can drain a closed vessel under vacuum or pressure.

The pump can be operated using steam, compressed air or other gases, and is manufactured in carbon steel or stainless steel.

OPERATION

Liquid flows by gravity into the pump through an inlet check valve, lifting the float. At this point, the motive fluid intake valve is closed while the vent valve is open. As the float reaches its highest position the motive fluid intake valve opens and the vent valve closes, allowing the motive fluid to enter the pump body. The pressure in the pump builds up just enough to overcome backpressure.

The pressurized liquid opens the outlet check valve and the discharge starts. The liquid discharged may be quantified through a special counter, enabling the pump to function as a reliable flow meter.

When the float reaches its lower position the motive fluid intake valve closes and the vent valve opens allowing the liquid to fill the pump once again, repeating the cycle.

MAIN FEATURES

- Hardened stainless steel wear parts.
- High-endurance inconel springs.
- Low filling head to minimize installation space.
- No electric requirements or NPSH issues.
- Suitable for hazardous environments.
- Low running costs.

OPTIONS: Level gauge.
 Stroke counters.
 Stainless steel construction.

USE: To lift steam condensate and other liquids compatible with the construction.

AVAILABLE MODELS: PPA14 – carbon steel.

SIZES: 3" x 2"; DN 80 x 50.

CONNECTIONS: Flanged EN 1092-1 PN 16.
 Flanged ASME B16.5 Class 150.
 Female threaded ISO 7 Rp (threaded flanges).
 Others on request.

INSTALLATION: Horizontal installation. An example is shown in Fig. 1. See IMI – Installation and maintenance instructions.

MOTIVE MEDIUM: Saturated steam, compressed air, nitrogen and other gases.



BODY LIMITING CONDITIONS *		
	ALLOWABLE PRESSURE	RELATED TEMPERATURE
PN 16	16 bar	50 °C
	15 bar	100 °C
	12,7 bar	200 °C
	12 bar	250 °C
CLASS 150	16 bar	50 °C
	12,6 bar	200 °C

* Rating according to EN 1092-1:2018.

CE MARKING – GROUP 2 (PED – European Directive)	
PN 16	Category
DN 80 x 50	3 (CE marked)

LIMITING CONDITIONS

Liquid specific gravity	0,8 to 1
Maximum viscosity	5 °Engler
Maximum motive inlet pressure	10 bar
Minimum motive inlet pressure	1 bar
Maximum operating temperature	185 °C
Minimum operating temperature	0 °C
Pump discharge per cycle	25 L

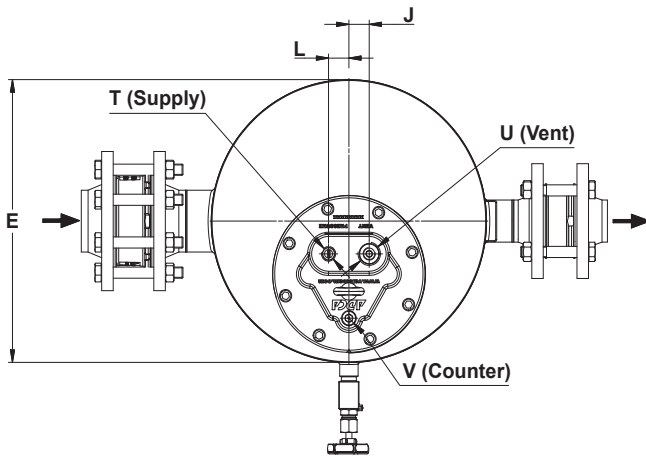
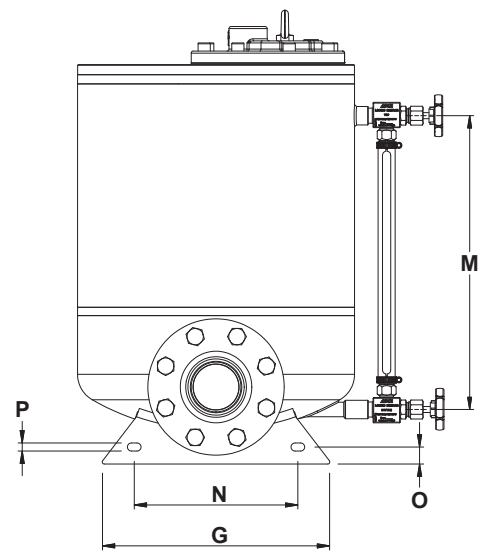
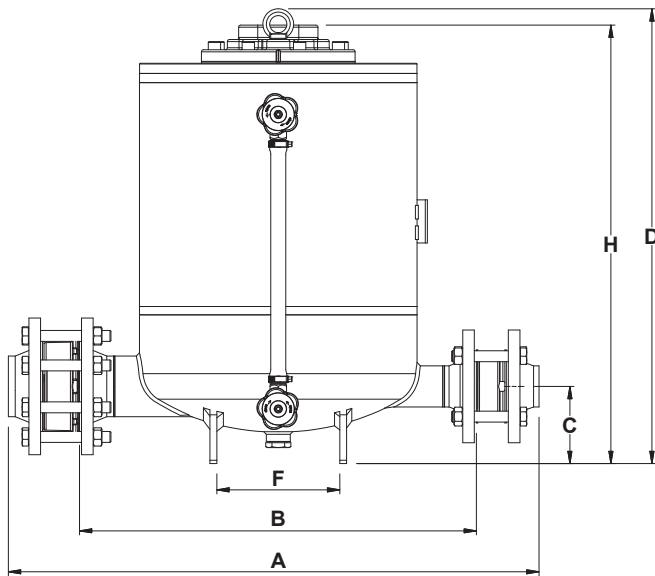

DIMENSIONS (mm)

SIZE	A*	B	C	D	E	F	G	H	J	L	M	N	O	P	T**	U**	V**	WGT. (kg)	VOL. (L)
DN 80 x 50	775	580	113	665	406	200	333	642	30	30	435	228	25	12	1/2"	1"	1/2"	123	68

* With EN 1092-1 welding neck flanges. Dimensions may differ if ASME B16.5 flanges or ISO 7 Rp female threaded flanges are requested. Consult the manufacturer.

** As standard, in versions manufactured with EN 1092-1 PN 16 flanges, these connections are female threaded ISO 7 Rp. In versions with ASME B16.5 flanges, these connections are female threaded NPT.

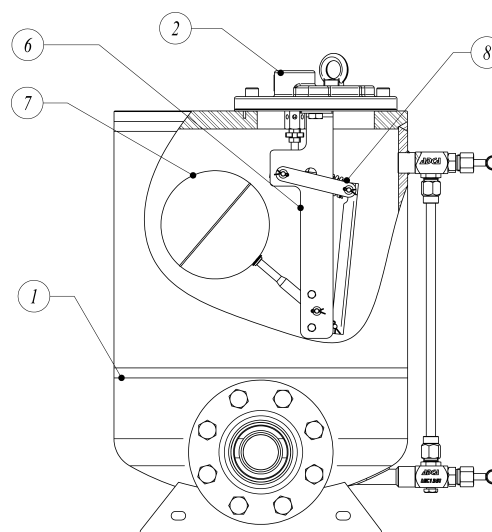
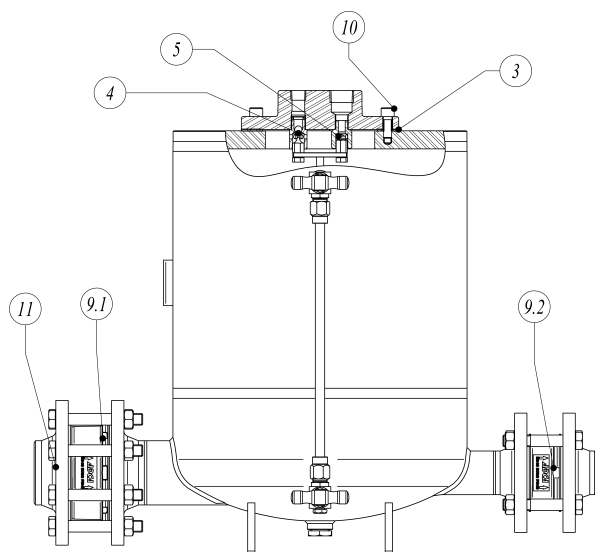

MATERIALS		
POS. N°	DESIGNATION	MATERIAL
1	Pump body	P265GH / 1.0425; P235GH / 1.0345; S235JR / 1.0038
2	Cover	GJS-400-15 / 0.7040 ; A216 WCB / 1.0619
3	* Cover gasket	Stainless steel / Graphite
4	* Intake valve/seat assembly	Stainless steel
5	* Exhaust valve/seat assembly	Stainless steel
6	Internal mechanism	Stainless steel
7	* Float	Stainless steel
8	* Spring assembly (2 pcs.)	Inconel
9.1	* Outlet check valve	A351 CF8M / 1.4408
9.2	* Inlet check valve	A351 CF8M / 1.4408
10	Bolts	Steel 8.8
11	Counter flanges	P250GH / 1.0460

* Available spare parts.

STROKE COUNTER

A stroke counter can be screwed onto a respective female threaded connection on the pump cover. Mechanical and digital versions are available. The mechanical version requires that the following conditions are met.

LIMITING CONDITIONS *	
Minimum motive pressure (steam)	6 bar
Minimum motive pressure (compressed air and nitrogen)	5 bar
Minimum system backpressure (steam)	700 mbar *
Minimum system backpressure (compressed air and nitrogen)	700 mbar *

* The pump outlet check valve can be supplied with a stronger spring to simulate increased system backpressure. Consult manufacturer.

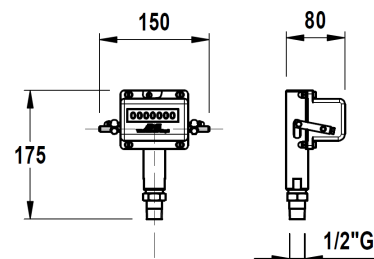

The digital version is composed of sensor and remote stroke counter. The device can be tailor made to meet customer requirements and is not dependent on the process condition. The standard unit is battery powered, features an LCD display and optional volt-free output connection for remote monitorization. Consult manufacturer.

SIZING

To accurately size a pressure operated pump, the following information must be provided:

1. The condensate load (kg/h).
2. The operating medium (steam, compressed air or other gases) and its pressure.
3. The total lift or backpressure in bar the pump will have to overcome. This includes the change in fluid level elevation after the pump (0.0981 bar/m of lift), plus pressure in the return piping, plus the pressure drop caused by pipe friction and other system components.
4. Available filling head (see Fig. 1) in mm or any other dimension that allows its determination.

MATERIALS			
POS. N°	DESIGNATION	POS. N°	DESIGNATION
2	Receiver	5	Pump
3	Ball valve	6	Disc check valve
4	Y strainer	7	Steam trap

CAPACITY CORRECTION FACTOR FOR GASES OTHER THAN STEAM					
% Backpressure vs Motive pressure (BP/MP)	10%	30%	50%	70%	90%
Correction factor	1,04	1,08	1,12	1,18	1,28

Table 1

RECEIVER

A receiver is recommended to temporarily hold the liquid and prevent any flooding of the equipment, while the pump is performing a pumping cycle. A definable length of large diameter pipe can be used.

Suggested receiver sizes are shown in Table 3.

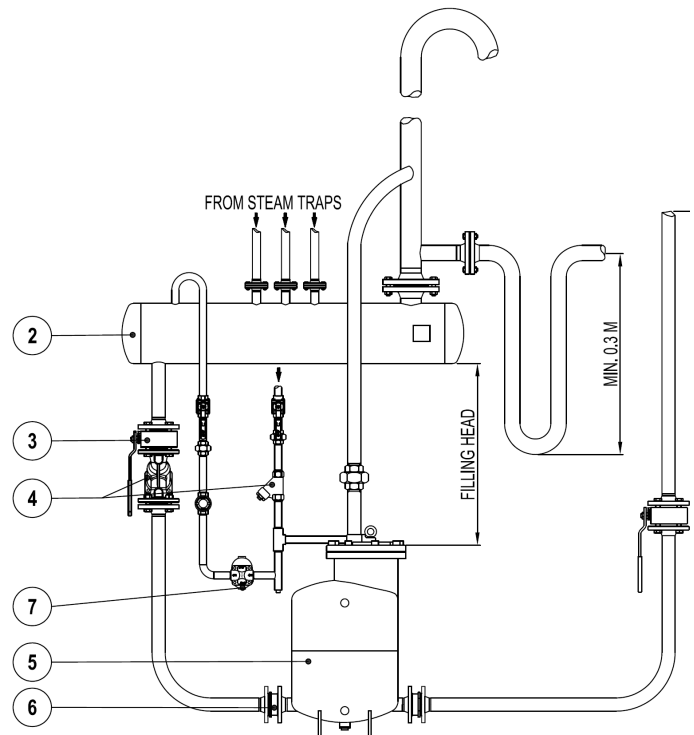

Fig. 1

CAPACITY CORRECTION FACTORS FOR FILLING HEADS OTHER THAN 300 mm				
PUMP SIZE	FILLING HEAD (mm)			
	150	300	600	900
3" x 2" DN 80 x 50	0,9	1	1,08	1,2

Table 2

RECEIVER	
PUMP SIZE	3" x 2" DN 80 x 50
Pipe Ø x lenght	323 x 1000

Table 3

FLOW RATE (kg/h) INSTALLATION WITH 300 mm FILLING HEAD ABOVE THE PUMP COVER		
MOTIVE PRESSURE (bar)	TOTAL LIFT (bar)	3" x 2" DN 80 x 50
1	0,35	3710
1,7		5470
3,5		5820
5		5970
7		6010
10		6290
1,7	1	3570
3,5		5160
5		5360
7		5470
10		5790
2,5	1,5	3435
3,5		4835
5		4980
7		5080
10		5390
3,5	3	2890
4		3440
5		3780
7		4040
10		4430
4,5	4	2505
5		2680
7		2990
10		3385

Table 4 (based on liquid specific gravity of 0,9 to 1,0)

Example

Condensate load 3500 kg/h
 Filling head 150 mm
 Motive fluid Compressed air
 Available pressure 7 bar
 Vertical lift after pump 10 m
 Return piping pressure 1,2 bar
 Piping friction pressure drop Negligible

Calculations:

Total backpressure: $1,2 \text{ bar} + (10 \text{ m} \times 0,0981) = 2,181$ bar. Assuming steam as motive medium at a pressure of 7 bar and a total backpressure of 3 bar, then according to Table 4 a DN 80 x 50 pump, with a capacity of 4040 kg/h, is the recommended size.

Filling head correction:

With 150 mm filling head the correction factor from Table 2 is 0,9. The corrected capacity is thus $4040 \text{ kg/h} \times 0,9 = 3636 \text{ kg/h}$.

Correction for air as a motive medium:

The % backpressure is $2,181 \text{ bar} / 7 \text{ bar} = 31\%$. The correction factor from Table 2 is 1,08. The corrected capacity is thus $3636 \text{ kg/h} \times 1,08 = 3926,88 \text{ kg/h}$, and so, a DN 80 x 50 pump is still the recommended size.

TYPICAL APPLICATIONS

CONDENSATE RECOVERY IN A OPEN LOOP SYSTEM

The pump transfers high temperature condensate without cavitation problems.

The vent line must be unrestricted and self draining to the receiver.

MATERIALS			
POS. N°	DESIGNATION	POS. N°	DESIGNATION
1	Heat exchanger	5	Pump
2	Receiver	6	Disc check valve
3	Ball valve	7	Steam trap
4	Y strainer	8	Air vent

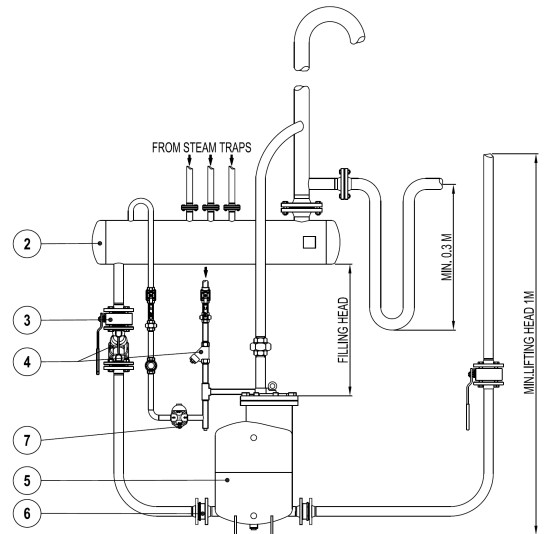

REMOVAL OF CONDENSATE UNDER PRESSURE WITH PUMP AND STEAM TRAP COMBINATION

The pump is installed in a closed loop with its vent connected to a pressurized receiver.

When steam pressure is sufficient to overcome backpressure, the steam trap operates. As soon as, e.g., the equipment's control valve starts to modulate, the steam pressure will decrease (even vacuum can occur). The lower differential pressure decreases the steam trap ability to discharge, causing the condensate level to rise inside the body of the pump. Once the pump float reaches its higher position, the intake valve opens and steam replaces the necessary positive pressure to pump out the condensate.

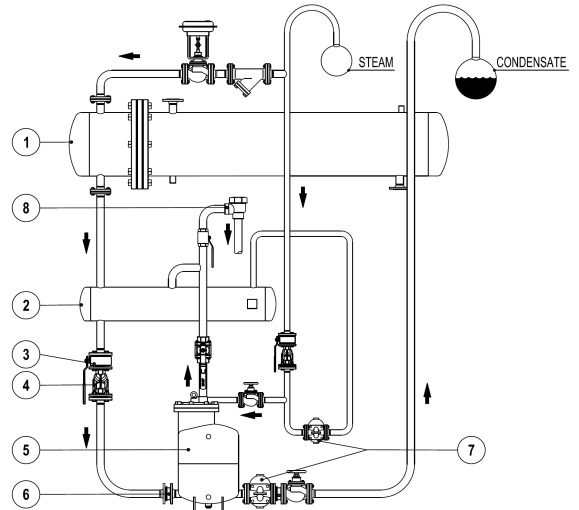

DRAINAGE OF A SINGLE UNIT UNDER VACUUM

This configuration works with units operating with a minimum absolute pressure of 0,2 bar.

For proper operation the filling head (H1) must range between 1 and 2 meters. The lift (H) must be as minimum as possible, but never less than 1 meter, otherwise a siphon with height (H2) is required.

Steam must be used as motive medium, and its maximum pressure should not exceed 3 bar.

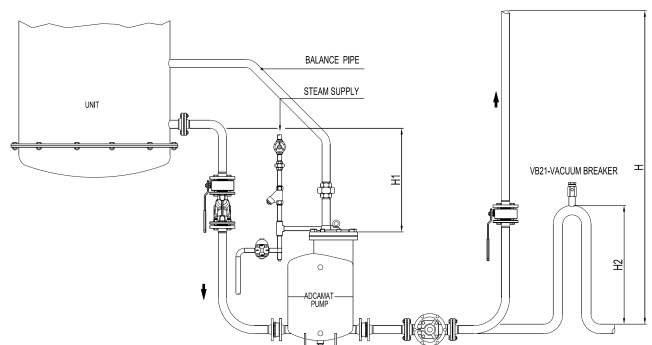

Алматы (7273)495-231
Ангарск (3955)60-70-56
Архангельск (8182)63-90-72
Астрахань (8512)99-46-04
Барнаул (3852)73-04-60
Белгород (4722)40-23-64
Благовещенск (4162)22-76-07
Брянск (4832)59-03-52
Владивосток (423)249-28-31
Владикавказ (8672)28-90-48
Владимир (4922)49-43-18
Волгоград (844)278-03-48
Вологда (8172)26-41-59
Воронеж (473)204-51-73
Екатеринбург (343)384-55-89

Иваново (4932)77-34-06
Ижевск (3412)26-03-58
Иркутск (395)279-98-46
Казань (843)206-01-48
Калининград (4012)72-03-81
Калуга (4842)92-23-67
Кемерово (3842)65-04-62
Киров (8332)68-02-04
Коломна (4966)23-41-49
Кострома (4942)77-07-48
Краснодар (861)203-40-90
Красноярск (391)204-63-61
Курск (4712)77-13-04
Курган (3522)50-90-47
Липецк (4742)52-20-81

Магнитогорск (3519)55-03-13
Москва (495)268-04-70
Мурманск (8152)59-64-93
Набережные Челны (8552)20-53-41
Нижний Новгород (831)429-08-12
Новокузнецк (3843)20-46-81
Ноябрьск (3496)41-32-12
Новосибирск (383)227-86-73
Омск (3812)21-46-40
Орел (4862)44-53-42
Оренбург (3532)37-68-04
Пенза (8412)22-31-16
Петрозаводск (8142)55-98-37
Псков (8112)59-10-37
Пермь (342)205-81-47

Ростов-на-Дону (863)308-18-15
Рязань (4912)46-61-64
Самара (846)206-03-16
Санкт-Петербург (812)309-46-40
Саратов (845)249-38-78
Севастополь (8692)22-31-93
Саранск (8342)22-96-24
Симферополь (3652)67-13-56
Смоленск (4812)29-41-54
Сочи (862)225-72-31
Ставрополь (8652)20-65-13
Сургут (3462)77-98-35
Сыктывкар (8212)25-95-17
Тамбов (4752)50-40-97
Тверь (4822)63-31-35

Тольятти (8482)63-91-07
Томск (3822)98-41-53
Тула (4872)33-79-87
Тюмень (3452)66-21-18
Ульяновск (8422)24-23-59
Улан-Удэ (3012)59-97-51
Уфа (347)229-48-12
Хабаровск (4212)92-98-04
Чебоксары (8352)28-53-07
Челябинск (351)202-03-61
Череповец (8202)49-02-64
Чита (3022)38-34-83
Якутск (4112)23-90-97
Ярославль (4852)69-52-93

Россия +7(495)268-04-70

Казахстан +7(7172)727-132

Киргизия +996(312)96-26-47