

Алматы (7273)495-231
Ангарск (3955)60-70-56
Архангельск (8182)63-90-72
Астрахань (8512)99-46-04
Барнаул (3852)73-04-60
Белгород (4722)40-23-64
Благовещенск (4162)22-76-07
Брянск (4832)59-03-52
Владивосток (423)249-28-31
Владикавказ (8672)28-90-48
Владимир (4922)49-43-18
Волгоград (844)278-03-48
Вологда (8172)26-41-59
Воронеж (473)204-51-73
Екатеринбург (343)384-55-89

Иваново (4932)77-34-06
Ижевск (3412)26-03-58
Иркутск (395)279-98-46
Казань (843)206-01-48
Калининград (4012)72-03-81
Калуга (4842)92-23-67
Кемерово (3842)65-04-62
Киров (8332)68-02-04
Коломна (4966)23-41-49
Кострома (4942)77-07-48
Краснодар (861)203-40-90
Красноярск (391)204-63-61
Курск (4712)77-13-04
Курган (3522)50-90-47
Липецк (4742)52-20-81

Магнитогорск (3519)55-03-13
Москва (495)268-04-70
Мурманск (8152)59-64-93
Набережные Челны (8552)20-53-41
Нижний Новгород (831)429-08-12
Новокузнецк (3843)20-46-81
Ноябрьск (3496)41-32-12
Новосибирск (383)227-86-73
Омск (3812)21-46-40
Орел (4862)44-53-42
Оренбург (3532)37-68-04
Пенза (8412)22-31-16
Петрозаводск (8142)55-98-37
Псков (8112)59-10-37
Пермь (342)205-81-47

Ростов-на-Дону (863)308-18-15
Рязань (4912)46-61-64
Самара (846)206-03-16
Санкт-Петербург (812)309-46-40
Саратов (845)249-38-78
Севастополь (8692)22-31-93
Саранск (8342)22-96-24
Симферополь (3652)67-13-56
Смоленск (4812)29-41-54
Сочи (862)225-72-31
Ставрополь (8652)20-65-13
Сургут (3462)77-98-35
Сыктывкар (8212)25-95-17
Тамбов (4752)50-40-97
Тверь (4822)63-31-35

Тольятти (8482)63-91-07
Томск (3822)98-41-53
Тула (4872)33-79-87
Тюмень (3452)66-21-18
Ульяновск (8422)24-23-59
Улан-Удэ (3012)59-97-51
Уфа (347)229-48-12
Хабаровск (4212)92-98-04
Чебоксары (8352)28-53-07
Челябинск (351)202-03-61
Череповец (8202)49-02-64
Чита (3022)38-34-83
Якутск (4112)23-90-97
Ярославль (4852)69-52-93

Россия +7(495)268-04-70

Казахстан +7(7172)727-132

Киргизия +996(312)96-26-47

<https://adca.nt-rt.ru/> || acd@nt-rt.ru



BUILT-IN ELECTRICAL CONDUCTIVITY SENSORS

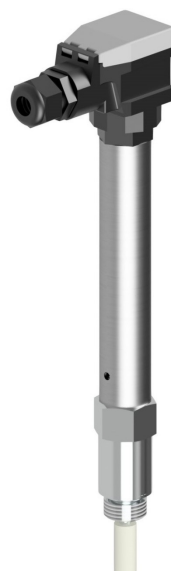

TDS CONDUCTIVITY PROBE INLINE CONDUCTIVITY MEASUREMENT SPS-21

DESCRIPTION

The ADCATrol SPS-21 conductivity probe is used to measure the conductivity (TDS) of the superheated water of boilers or condensate. The probe is used in conjunction with an ADCATrol BCS-211 controller and a VPC series TDS blowdown control valve.

The water contains impurities in form of dissolved solids and solids in suspension, whose concentration increases when it's vaporized. Water treatment can reduce impurities to a certain level, but it does not eliminate them completely and, in certain conditions, it might even increase them. As steam production starts, the concentration of total dissolved solids (TDS) increases in the boiler's water. If the concentration is too high, contamination of steam may occur, resulting in system damage further ahead, such as corrosion and salt incrustations on thermal transference surfaces, among other problems.

This high concentration is harmful and is not acceptable in applications where steam is used for treatment of food, drinks and sterilization processes.

In order to limit the concentration of TDS to a suitable level, a certain amount of boiler water must be periodically eliminated (purge action) and replaced by treated water.

OPTIONS: Flanged sensor chamber.

USE: Superheated boiler water and condensate.

AVAILABLE MODELS: SPS-21 – conductivity probe.

SIZES AND CONNECTIONS: 1/2" male threaded ISO 228.

ELECTRICAL CONNECTIONS: Plug connection with screw terminals, traction relief.

INSTALLATION: Horizontal installation.
Vertical installation possible, under special request.
See IMI – Installation and maintenance instructions.



LIMITING CONDITIONS	
Maximum operating pressure	32 bar
Maximum operating temperature	239 °C
Maximum ambient temperature	100 °C
Minimum distance from boiler tubes	20 mm
Maximum cable length	100 m
Cable gland	M16 x 1,5
Minimum conductivity *	1 uS/cm

* Lower ranges available on request.

TECHNICAL DATA	
TYPE	SPS-21
Component mark	TUV ID: 0000006175
Protection as per DIN VDE 0470	IP 65

MATERIALS	
DESIGNATION	MATERIAL
Probe housing	Stainless steel
Probe rod	Stainless steel
Insulation	PTFE
Socket	Polyamid
Sealing ring	Soft iron
Measuring flange	P250GH / 1.0460

DIMENSIONS

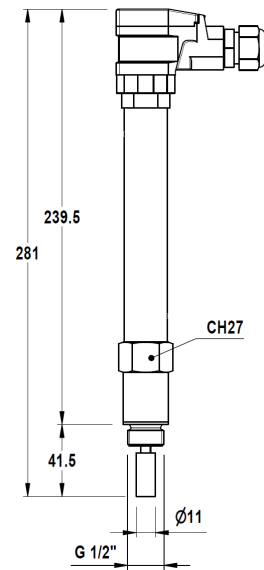

TYPE F-2132 FLANGED SENSOR CHAMBER (SANDWICHED DESIGN)

MATERIALS	
POS. N°	DESIGNATION
1	F-2132 flanged sensor chamber
2	SPS-21 conductivity probe
3	Compression fitting for sample collection *

* Optional.

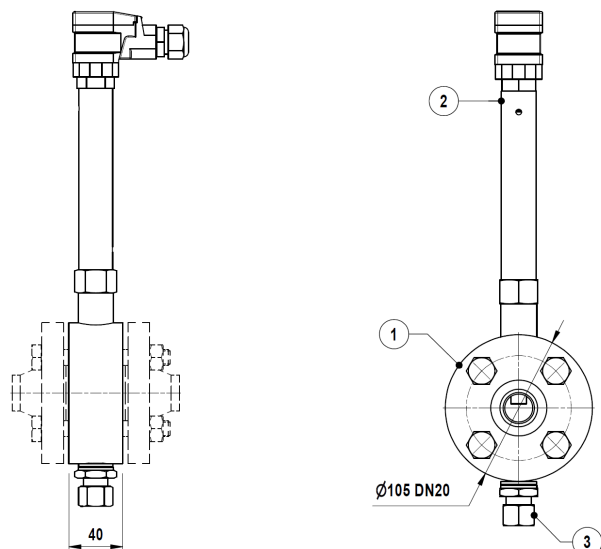

Remarks: Can be fitted into a "T" connection or into our standard chamber, providing that the probe is always in contact with the water. Any metallic parts near the probe must be at a minimum distance of 20 mm from the central end pole.

TYPICAL INSTALLATIONS

FIRETUBE BOILER AND PNEUMATIC ACTUATED VALVE

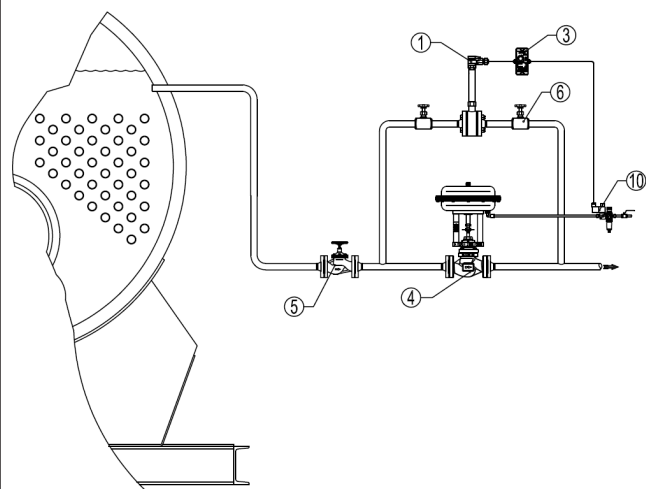

OPERATION

The VPC TDS blowdown control valve is programmed to open periodically, in order to purge a certain amount of water. The BCS controller will then measure the electrical conductivity of boiler water (closely related to the TDS) and compare it with the set point selected in the controller. It closes the valve after the purge if the measured value is lower, or it will keep the valve open until the measured value is below the set point, if it is higher.

To avoid energy waste due to boiler stand-by or low load, it is recommended to relate the system operation to the burner firing.

It is also recommended to install a heat recovery system (flash vessel, heat exchanger, etc) before connecting the wasted water to the BEX.

Remark: Sensor chamber is rotated 90° for catalogue only.

MATERIALS

POS. N°	DESIGNATION
1	ADCATrol SPS-21 TDS probe
3	ADCATrol BCS-211 TDS controller
4	ADCATrol VPC series TDS blowdown control valve
5	ADCA VF bellows sealed globe valve
6	ADCA NV400 needle valve
10	SV32C direct solenoid valve

WATER TUBE COIL BOILER – PROBE INSTALLED IN THE CONDENSATE RETURN LINE

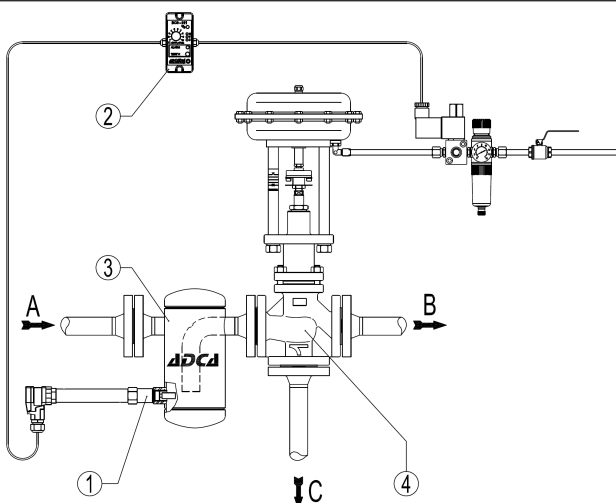

OPERATION

The BCS controller (2) is programmed to continuously measure (1) the electrical conductivity of boiler return condensate (closed related to the TDS) and compare it with the set point selected in the controller. It will invert the flow of the three way valve (4) from B to C if the measured value is higher, or keep the valve flow from A to B until the measured value exceed the set point.

The chamber (3) ensures that the probe (1) is always in contact with the measured medium (condensate).

It is recommended to install a heat recovery system (flash vessel, heat exchanger, etc.) before connecting the wasted condensate (C) to the BEX.

MATERIALS

POS. N°	DESIGNATION
1	ADCATrol SPS-21 TDS probe
2	ADCATrol BCS-211 TDS controller
3	Probe chamber
4	ADCATrol PV253 3 way control valve

WATER TUBE COIL BOILER – PROBE INSTALLED IN THE RECIRCULATING PIPE

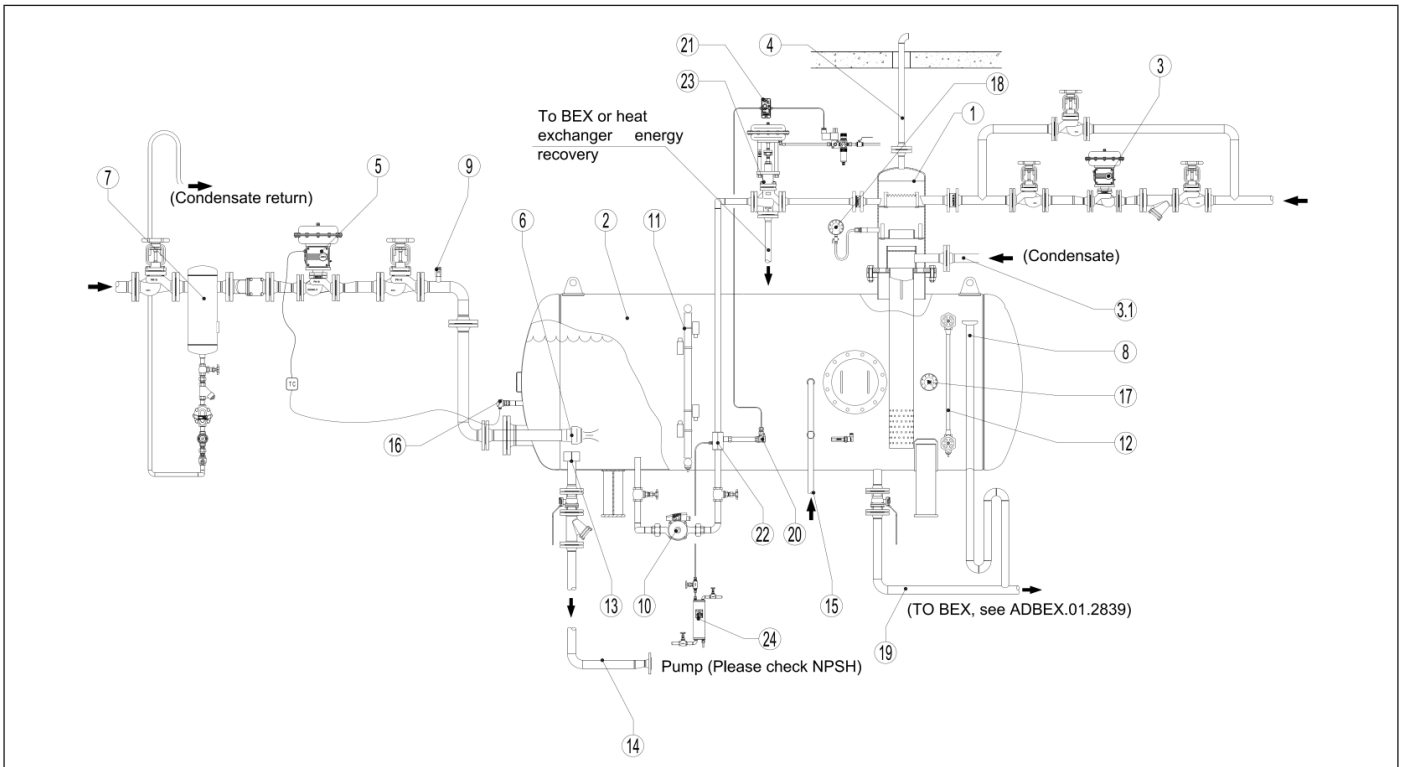

OPERATION

Similar to the previous example but, in this case, the pump (10) is re-circulating the make-up water across the probe (22).

MATERIALS	
POS. N°	DESIGNATION
20	ADCATrol SPS-21 TDS probe
21	ADCATrol BCS-211 TDS controller
22	Probe chamber
23	ADCATrol PV253 3 way control valve
24	ADCA SC32 sample cooling system

For complete description, see ADADGV (Atmospheric semi-deaerator ADG-V assembly drawing).

TDS CONDUCTIVITY PROBE INLINE CONDUCTIVITY MEASUREMENT SPS-33

DESCRIPTION

The ADCATrol SPS-33 conductivity probe is used to measure the conductivity (TDS) of the superheated water of boilers or condensate. The probe is used in conjunction with an ADCATrol BCS-211 controller and a VPC series TDS blowdown control valve.

The water contains impurities in form of dissolved solids and solids in suspension, whose concentration increases when it's vaporized. Water treatment can reduce impurities to a certain level, but it does not eliminate them completely and, in certain conditions, it might even increase them. As steam production starts, the concentration of total dissolved solids (TDS) increases in the boiler's water. If the concentration is too high, contamination of steam may occur, resulting in system damage further ahead, such as corrosion and salt incrustations on thermal transference surfaces (among other problems).

This high concentration is harmful and is not acceptable in applications where steam is used for treatment of food, drinks and sterilization processes.

In order to limit the concentration of TDS to a suitable level, a certain amount of boiler water must be periodically eliminated (purge action) and replaced by treated water.

OPTIONS: "T" piece type F-3220 for boiler and blowdown valve connection.

USE: Superheated boiler water and condensate.

AVAILABLE MODELS: SPS-33 – conductivity probe.

SIZES AND CONNECTIONS: 1/2" male threaded ISO 228.

ELECTRICAL CONNECTIONS: Plug connection with screw terminals, traction relief.

INSTALLATION: Horizontal installation.
Vertical installation possible, under special request.
See IMI – Installation and maintenance instructions.



FIRETUBE BOILER AND PNEUMATIC ACTUATED VALVE

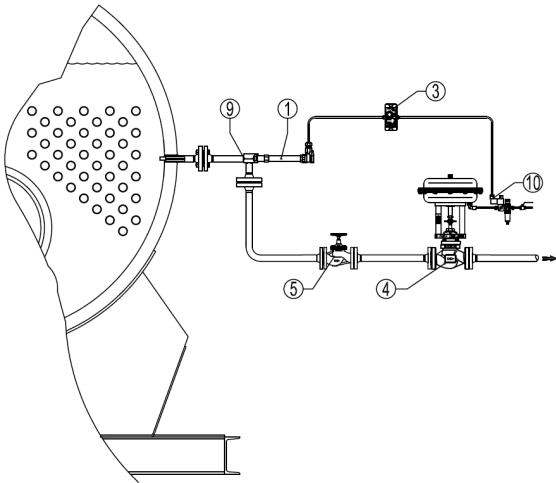

OPERATION

The BCS controller (3) is programmed to continuously measure the electrical conductivity (1) of boiler water (closely related to the TDS) and compare it with the set point selected in the controller. It will open the blowdown valve (4) if the measured value is higher, or keep the valve closed until the measured value exceeds the set point. It is recommended to install a heat recovery system (flash vessel, heat exchanger, etc) before connecting the wasted water to the BEX.

MATERIALS

POS. N°	DESIGNATION
1	ADCATrol SPS-33 TDS probe
3	ADCATrol BCS-211 TDS controller
4	ADCATrol VPC series TDS blowdown control valve
5	ADCA VF bellows sealed globe valve
9	Tee piece type F-3220
10	SV32C direct solenoid valve

Алматы (7273)495-231
Ангарск (3955)60-70-56
Архангельск (8182)63-90-72
Астрахань (8512)99-46-04
Барнаул (3852)73-04-60
Белгород (4722)40-23-64
Благовещенск (4162)22-76-07
Брянск (4832)59-03-52
Владивосток (423)249-28-31
Владикавказ (8672)28-90-48
Владимир (4922)49-43-18
Волгоград (844)278-03-48
Вологда (8172)26-41-59
Воронеж (473)204-51-73
Екатеринбург (343)384-55-89

Иваново (4932)77-34-06
Ижевск (3412)26-03-58
Иркутск (395)279-98-46
Казань (843)206-01-48
Калининград (4012)72-03-81
Калуга (4842)92-23-67
Кемерово (3842)65-04-62
Киров (8332)68-02-04
Коломна (4966)23-41-49
Кострома (4942)77-07-48
Краснодар (861)203-40-90
Красноярск (391)204-63-61
Курск (4712)77-13-04
Курган (3522)50-90-47
Липецк (4742)52-20-81

Магнитогорск (3519)55-03-13
Москва (495)268-04-70
Мурманск (8152)59-64-93
Набережные Челны (8552)20-53-41
Нижний Новгород (831)429-08-12
Новокузнецк (3843)20-46-81
Ноябрьск (3496)41-32-12
Новосибирск (383)227-86-73
Омск (3812)21-46-40
Орел (4862)44-53-42
Оренбург (3532)37-68-04
Пенза (8412)22-31-16
Петрозаводск (8142)55-98-37
Псков (8112)59-10-37
Пермь (342)205-81-47

Ростов-на-Дону (863)308-18-15
Рязань (4912)46-61-64
Самара (846)206-03-16
Санкт-Петербург (812)309-46-40
Саратов (845)249-38-78
Севастополь (8692)22-31-93
Саранск (8342)22-96-24
Симферополь (3652)67-13-56
Смоленск (4812)29-41-54
Сочи (862)225-72-31
Ставрополь (8652)20-65-13
Сургут (3462)77-98-35
Сыктывкар (8212)25-95-17
Тамбов (4752)50-40-97
Тверь (4822)63-31-35

Тольятти (8482)63-91-07
Томск (3822)98-41-53
Тула (4872)33-79-87
Тюмень (3452)66-21-18
Ульяновск (8422)24-23-59
Улан-Удэ (3012)59-97-51
Уфа (347)229-48-12
Хабаровск (4212)92-98-04
Чебоксары (8352)28-53-07
Челябинск (351)202-03-61
Череповец (8202)49-02-64
Чита (3022)38-34-83
Якутск (4112)23-90-97
Ярославль (4852)69-52-93

Россия +7(495)268-04-70

Казахстан +7(7172)727-132

Киргизия +996(312)96-26-47

<https://adca.nt-rt.ru/> || acd@nt-rt.ru