

Алматы (7273)495-231  
Ангарск (3955)60-70-56  
Архангельск (8182)63-90-72  
Астрахань (8512)99-46-04  
Барнаул (3852)73-04-60  
Белгород (4722)40-23-64  
Благовещенск (4162)22-76-07  
Брянск (4832)59-03-52  
Владивосток (423)249-28-31  
Владикавказ (8672)28-90-48  
Владимир (4922)49-43-18  
Волгоград (844)278-03-48  
Вологда (8172)26-41-59  
Воронеж (473)204-51-73  
Екатеринбург (343)384-55-89

Иваново (4932)77-34-06  
Ижевск (3412)26-03-58  
Иркутск (395)279-98-46  
Казань (843)206-01-48  
Калининград (4012)72-03-81  
Калуга (4842)92-23-67  
Кемерово (3842)65-04-62  
Киров (8332)68-02-04  
Коломна (4966)23-41-49  
Кострома (4942)77-07-48  
Краснодар (861)203-40-90  
Красноярск (391)204-63-61  
Курск (4712)77-13-04  
Курган (3522)50-90-47  
Липецк (4742)52-20-81

Магнитогорск (3519)55-03-13  
Москва (495)268-04-70  
Мурманск (8152)59-64-93  
Набережные Челны (8552)20-53-41  
Нижний Новгород (831)429-08-12  
Новокузнецк (3843)20-46-81  
Ноябрьск (3496)41-32-12  
Новосибирск (383)227-86-73  
Омск (3812)21-46-40  
Орел (4862)44-53-42  
Оренбург (3532)37-68-04  
Пенза (8412)22-31-16  
Петрозаводск (8142)55-98-37  
Псков (8112)59-10-37  
Пермь (342)205-81-47

Ростов-на-Дону (863)308-18-15  
Рязань (4912)46-61-64  
Самара (846)206-03-16  
Санкт-Петербург (812)309-46-40  
Саратов (845)249-38-78  
Севастополь (8692)22-31-93  
Саранск (8342)22-96-24  
Симферополь (3652)67-13-56  
Смоленск (4812)29-41-54  
Сочи (862)225-72-31  
Ставрополь (8652)20-65-13  
Сургут (3462)77-98-35  
Сыктывкар (8212)25-95-17  
Тамбов (4752)50-40-97  
Тверь (4822)63-31-35

Тольятти (8482)63-91-07  
Томск (3822)98-41-53  
Тула (4872)33-79-87  
Тюмень (3452)66-21-18  
Ульяновск (8422)24-23-59  
Улан-Удэ (3012)59-97-51  
Уфа (347)229-48-12  
Хабаровск (4212)92-98-04  
Чебоксары (8352)28-53-07  
Челябинск (351)202-03-61  
Череповец (8202)49-02-64  
Чита (3022)38-34-83  
Якутск (4112)23-90-97  
Ярославль (4852)69-52-93

Россия +7(495)268-04-70

Казахстан +7(7172)727-132

Киргизия +996(312)96-26-47

<https://adca.nt-rt.ru/> || [acd@nt-rt.ru](mailto:acd@nt-rt.ru)

## UNIVERSAL PIPELINE CONNECTORS UCX90



## UNIVERSAL PIPELINE CONNECTORS UCX90

### DESCRIPTION

The UCX series pipeline connectors are used in steam systems where a simple and economic maintenance program is desired. Typical installations are drip service on steam lines, tracing applications and small process equipment. The four-bolt flange connector allows for fast trap replacement without disturbing the pipelines. The UCX connector fits the universal four-bolt swivel connection steam traps.

### MAIN FEATURES

Remains permanently in-line making the replacement of new traps easier and quicker.  
 Steam traps can swivel 360°, allowing any pipe orientation during installation.  
 The universal flange allows the trap to be positioned in the correct position, regardless of pipeline configuration.  
 Built-in strainer.

- OPTIONS:** Blowdown valve.
- USE:** Saturated and superheated steam.
- AVAILABLE MODELS:** UCX90 – stainless steel.
- SIZES:** 1/2" to 1"; DN 15 to DN 25.
- CONNECTIONS:** Female threaded ISO 7 Rp or NPT.  
 Flanged EN 1092-1 PN 100.  
 Flanged ASME B16.5 Class 600.  
 Socket weld (SW) ASME B16.11.
- INSTALLATION:** With the surface for swivel connection in a vertical plane (mechanical steam traps) or, alternatively, in an horizontal plane for thermostatic steam traps.  
 See IMI – Installation and maintenance instructions.



BODY LIMITING CONDITIONS		
FLANGED PN 100 *	FLANGED CLASS 600 **	RELATED TEMP.
ALLOWABLE PRESSURE	ALLOWABLE PRESSURE	
100 bar	100 bar	50 °C
100 bar	92,7 bar	250 °C
97,6 bar	80,4 bar	350 °C
88 bar	67,7 bar	450 °C

Operating pressure: 4 to 85 bar.  
 \* Acc. to EN 1092-1:2018. \*\* Acc. to EN 1759-1:2004.  
 Body limiting conditions PN 100 or below, depending on the type of connection adopted. Rating PN 100 for threaded and SW versions.

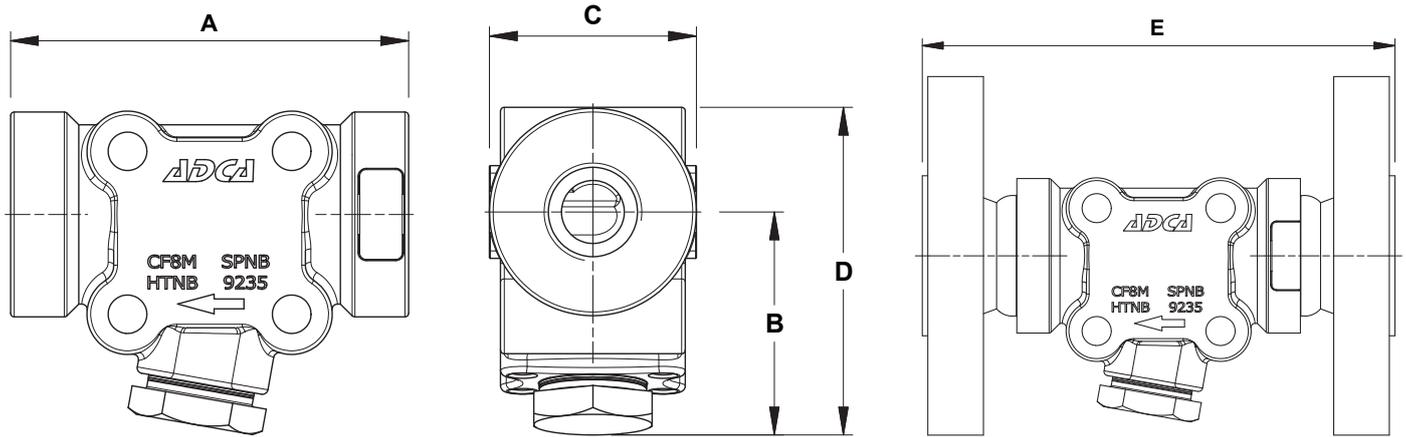

DIMENSIONS (mm)									
SIZE	THREADED / SW				WEIGHT (kg)	PN 100		CLASS 600	
	A	B	C	D		E	WEIGHT (kg)	E	WEIGHT (kg)
1/2" - DN 15	108	60	56	88	2,1	165	4,4	185	3,8
3/4" - DN 20	108	60	68	88	2,1	170	6	200	4,9
1" - DN 25	108	60	68	88	2	185	7,1	200	5,5

MATERIALS		
POS. N°	DESCRIPTION	MATERIAL
1	Body	A351 CF8M / 1.4408
2	Strainer cap	AISI 321 / 1.4541
3	* Strainer screen	AISI 304 / 1.4301
4	* Spiral wound gasket	Stainless steel / Graphite

\* Available spare parts.

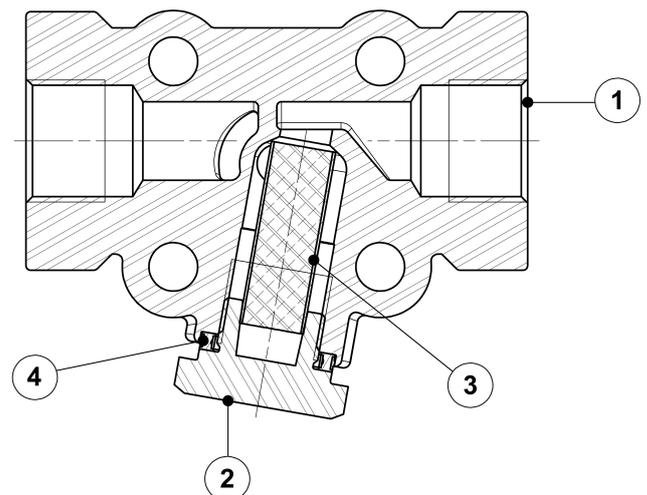

**Алматы** (7273)495-231  
**Ангарск** (3955)60-70-56  
**Архангельск** (8182)63-90-72  
**Астрахань** (8512)99-46-04  
**Барнаул** (3852)73-04-60  
**Белгород** (4722)40-23-64  
**Благовещенск** (4162)22-76-07  
**Брянск** (4832)59-03-52  
**Владивосток** (423)249-28-31  
**Владикавказ** (8672)28-90-48  
**Владимир** (4922)49-43-18  
**Волгоград** (844)278-03-48  
**Вологда** (8172)26-41-59  
**Воронеж** (473)204-51-73  
**Екатеринбург** (343)384-55-89

**Иваново** (4932)77-34-06  
**Ижевск** (3412)26-03-58  
**Иркутск** (395)279-98-46  
**Казань** (843)206-01-48  
**Калининград** (4012)72-03-81  
**Калуга** (4842)92-23-67  
**Кемерово** (3842)65-04-62  
**Киров** (8332)68-02-04  
**Коломна** (4966)23-41-49  
**Кострома** (4942)77-07-48  
**Краснодар** (861)203-40-90  
**Красноярск** (391)204-63-61  
**Курск** (4712)77-13-04  
**Курган** (3522)50-90-47  
**Липецк** (4742)52-20-81

**Магнитогорск** (3519)55-03-13  
**Москва** (495)268-04-70  
**Мурманск** (8152)59-64-93  
**Набережные Челны** (8552)20-53-41  
**Нижний Новгород** (831)429-08-12  
**Новокузнецк** (3843)20-46-81  
**Ноябрьск** (3496)41-32-12  
**Новосибирск** (383)227-86-73  
**Омск** (3812)21-46-40  
**Орел** (4862)44-53-42  
**Оренбург** (3532)37-68-04  
**Пенза** (8412)22-31-16  
**Петрозаводск** (8142)55-98-37  
**Псков** (8112)59-10-37  
**Пермь** (342)205-81-47

**Ростов-на-Дону** (863)308-18-15  
**Рязань** (4912)46-61-64  
**Самара** (846)206-03-16  
**Санкт-Петербург** (812)309-46-40  
**Саратов** (845)249-38-78  
**Севастополь** (8692)22-31-93  
**Саранск** (8342)22-96-24  
**Симферополь** (3652)67-13-56  
**Смоленск** (4812)29-41-54  
**Сочи** (862)225-72-31  
**Ставрополь** (8652)20-65-13  
**Сургут** (3462)77-98-35  
**Сыктывкар** (8212)25-95-17  
**Тамбов** (4752)50-40-97  
**Тверь** (4822)63-31-35

**Тольятти** (8482)63-91-07  
**Томск** (3822)98-41-53  
**Тула** (4872)33-79-87  
**Тюмень** (3452)66-21-18  
**Ульяновск** (8422)24-23-59  
**Улан-Удэ** (3012)59-97-51  
**Уфа** (347)229-48-12  
**Хабаровск** (4212)92-98-04  
**Чебоксары** (8352)28-53-07  
**Челябинск** (351)202-03-61  
**Череповец** (8202)49-02-64  
**Чита** (3022)38-34-83  
**Якутск** (4112)23-90-97  
**Ярославль** (4852)69-52-93

**Россия** +7(495)268-04-70

**Казахстан** +7(7172)727-132

**Киргизия** +996(312)96-26-47